

# WIRING DIAGRAM

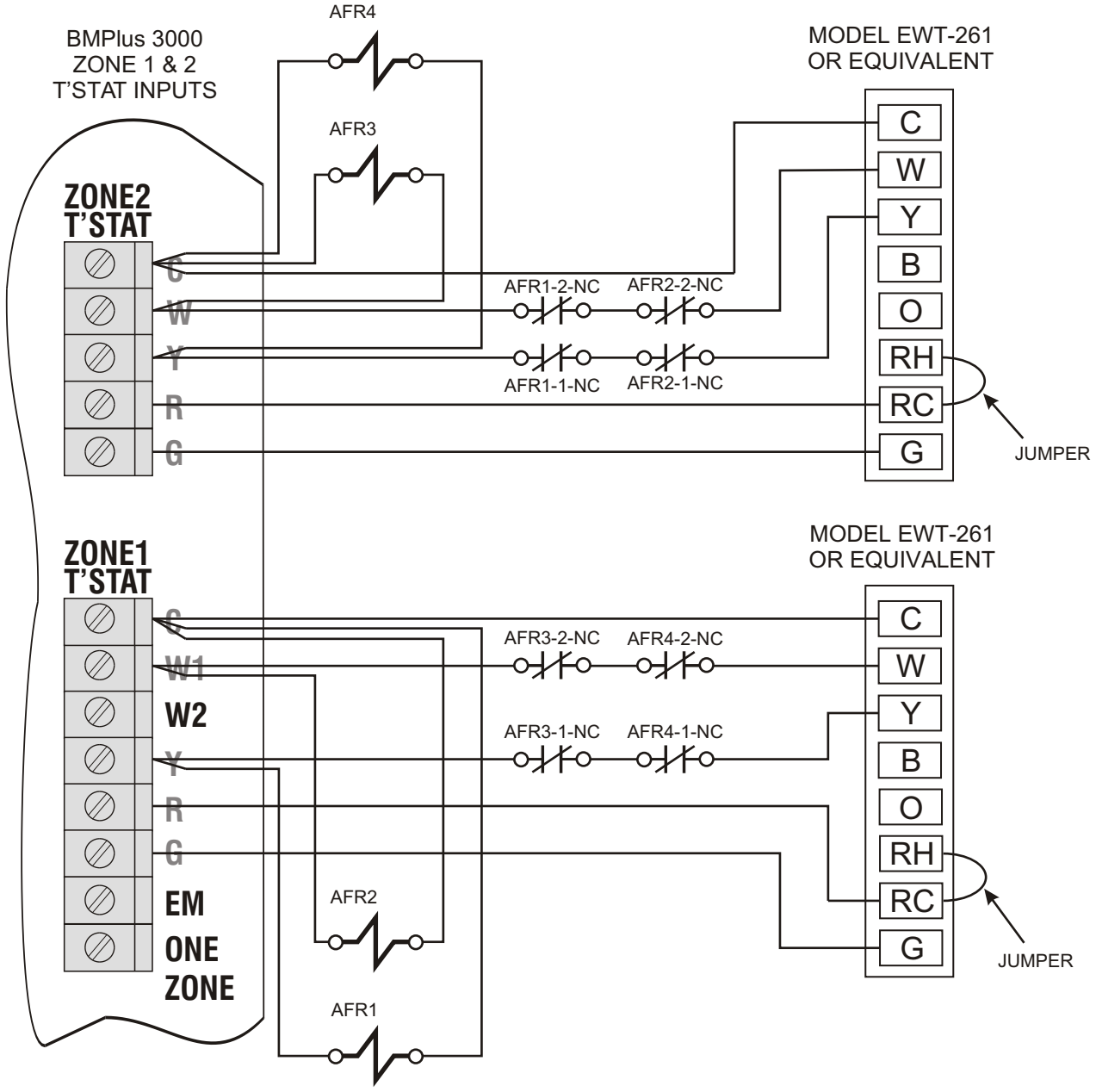

\*NOTE: AFR(1-4) -- DPDT RELAY W/ 24VAC COIL

**EWC**<sup>®</sup>

CONTROLS INC.

Englishtown, NJ 07726

DRAWING BY:  
EDK

DWG NAME: BMPlus3000 -- WIRED W/ ZONE  
PRIORITY LOCK-OUT RELAYS

DATE:  
03/08/05

SIZE:  
A

REV:  
A

DWG NO:  
090512A0089

SHEET: 1 OF 1

COPYRIGHT © EWC CONTROLS INC.  
ALL RIGHTS RESERVED

DISCLAIMER: EWC Controls Inc., Cannot be held liable for the use or misuse of this supplied information. It is the responsibility of the user to determine the suitability of the application. Malfunctions, improper operation, and/or subsequent damage to any related equipment or property damage as a result of using this supplied information is the responsibility of the user. EWC Controls Inc., is not responsible for any misapplications including, but not limited to negligence, defect in product(s), system incompatibility, poor workmanship and/or installation.