

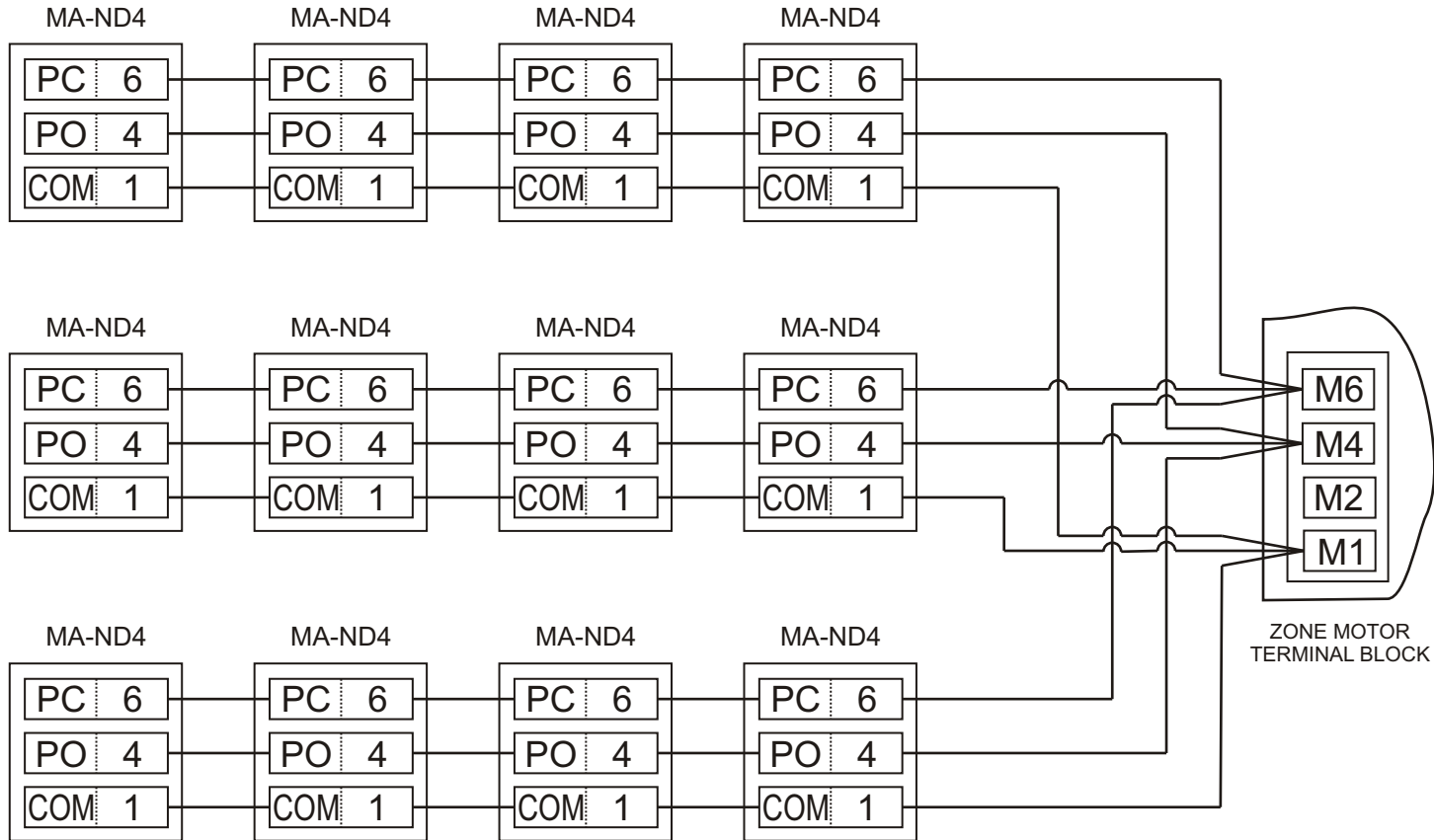

WIRING DIAGRAM



NOTE:
 THE MAXIMUM NUMBER OF DAMPERS FOR THIS CONFIGURATION IS 12. IF MORE THAN 12 DAMPERS ARE REQUIRED, AN ISOLATION RELAY AND SEPARATE TRANSFORMER ARE REQUIRED, REFER TO THE ZONE PANEL TECHNICAL BULLETIN FOR PROPER WIRING.

 EWC [®] CONTROLS INC. Englishtown, NJ 07726	DRAWING BY: EDK		DWG NAME: MODEL MA-ND4 – MULTIPLE MOTOR ACTUATORS WIRED TO ONE ZONE.		DATE: 01/25/11
	SIZE: A	REV: E	DWG NO: 090512A0041		
	SHEET: 1 OF 1		COPYRIGHT © EWC CONTROLS INC. ALL RIGHTS RESERVED		

DISCLAIMER: EWC Controls Inc., Cannot be held liable for the use or misuse of this supplied information. It is the responsibility of the user to determine the suitability of the application. Malfunctions, improper operation, and/or subsequent damage to any related equipment or property damage as a result of using this supplied information is the responsibility of the user. EWC Controls Inc., is not responsible for any misapplications including, but not limited to negligence, defect in products(s), system incompatibility, poor workmanship and/or installation.