

WIRING DIAGRAM

UZC-3C
HVAC SYSTEM
OUTPUT

SINGLE STAGE HEATPUMP W/ 1 OR 2 STAGE FURNACE

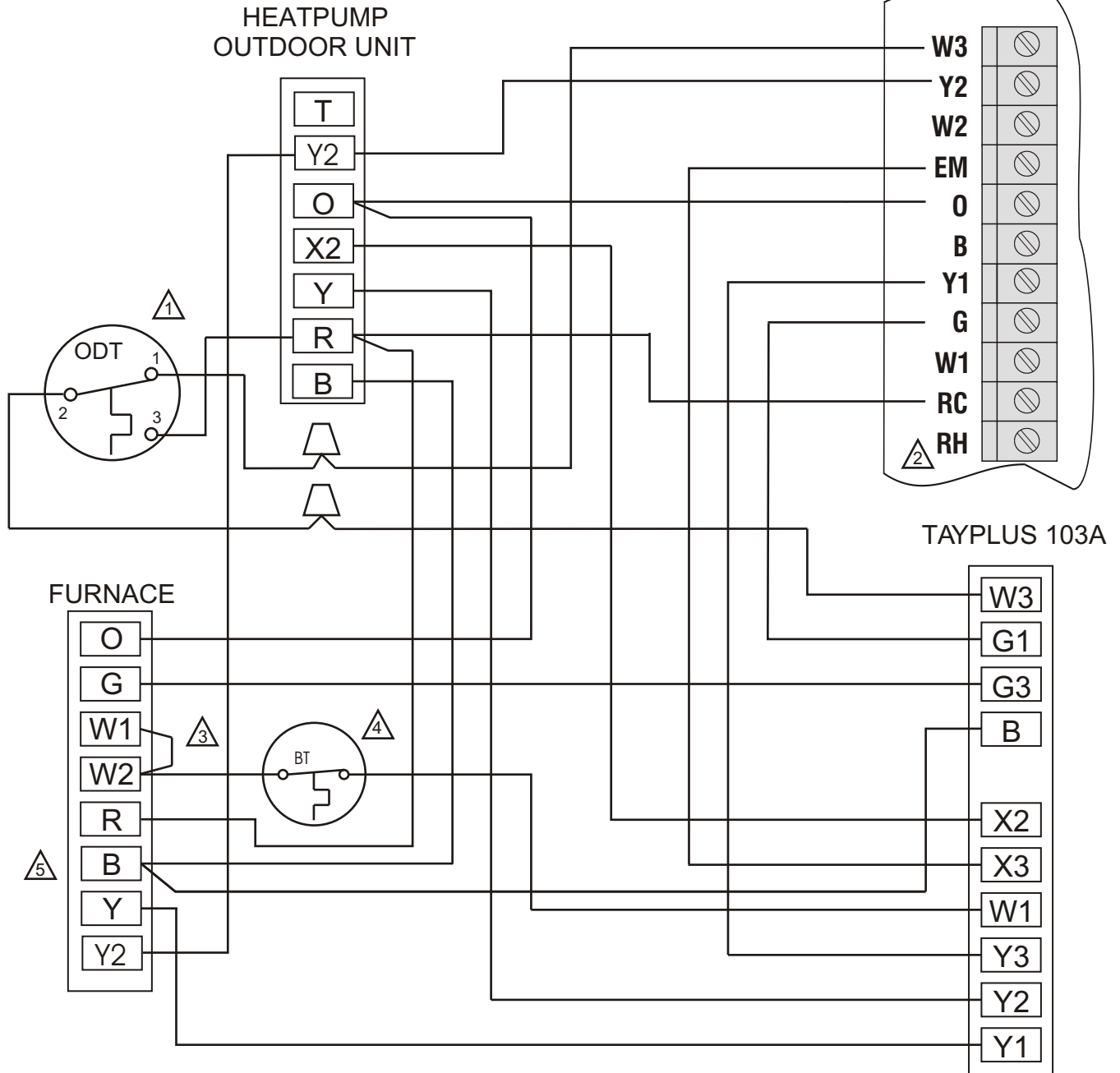

- ⚠️ TO LOCK OUT GAS FURNACE AT OUTDOOR TEMPERATURES ABOVE ODT SET POINT
DO NOT CONNECT WIRE TO PANEL TERMINAL 'W2' AND TERMINAL '1' ON ODT
- ⚠️ NO JUMPER REQUIRED IF RC/RH LINK IS NOT CUT
- ⚠️ THIS JUMPER REQUIRED ONLY FOR 2 STAGE FURNACE APPLICATIONS
- ⚠️ BONNET THERMOSTAT MODEL TAYPLUS101A REQUIRED FOR OIL FURNACE APPLICATIONS
- ⚠️ DO NOT CONNECT 'B' TO UZC-3C

EWC[®]
CONTROLS INC.

Englishtown, NJ 07726

DRAWING BY:
DJH

DWG NAME: UZC-3C DUAL FUEL W/ TAYPLUS103A
W/ 2 STAGE HEAT PUMP -- RESTRICTED

DATE:
04/28/04

SIZE:
A

REV:
B

DWG NO:
090512A0032

SHEET: 1 OF 1

COPYRIGHT © EWC CONTROLS INC.
ALL RIGHTS RESERVED

DISCLAIMER: EWC Controls Inc., Cannot be held liable for the use or misuse of this supplied information. It is the responsibility of the user to determine the suitability of the application. Malfunctions, improper operation, and/or subsequent damage to any related equipment or property damage as a result of using this supplied information is the responsibility of the user. EWC Controls Inc., is not responsible for any misapplications including, but not limited to negligence, defect in products(s), system incompatibility, poor workmanship and/or installation.