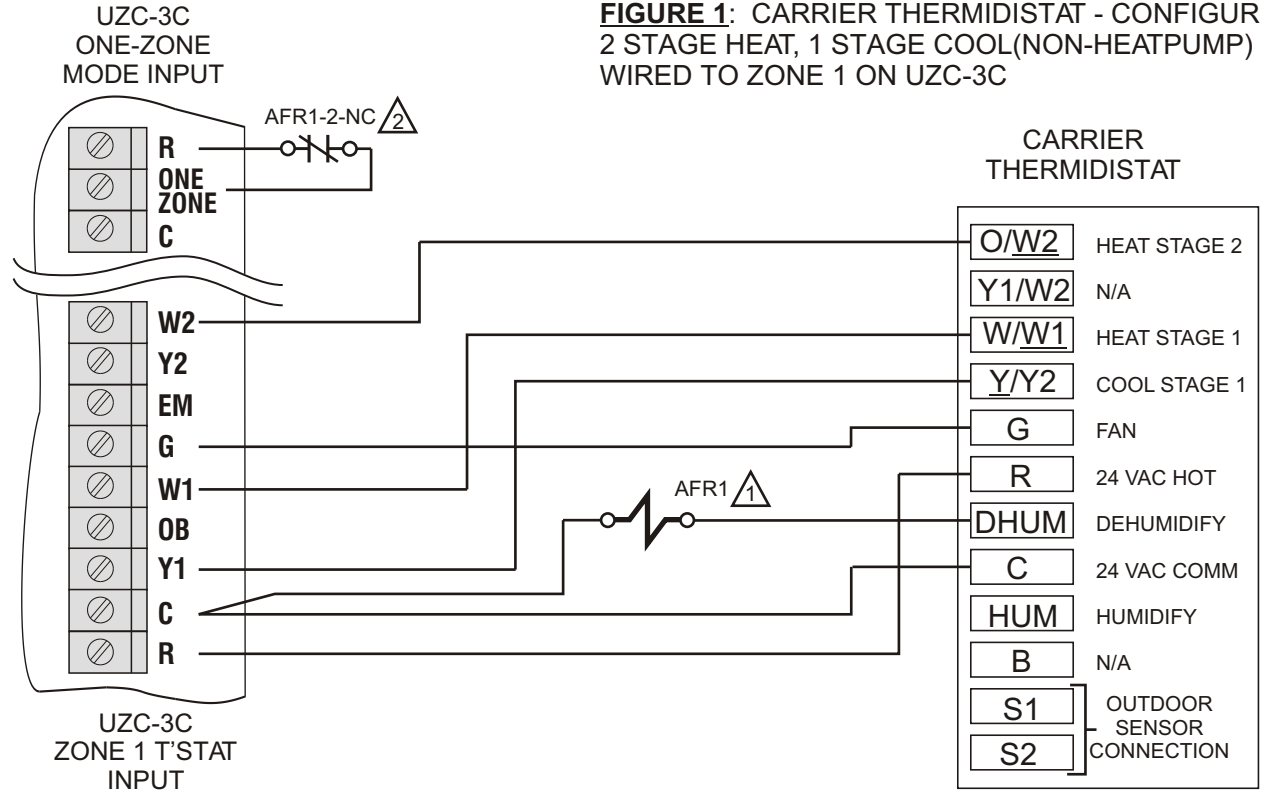



# WIRING DIAGRAM



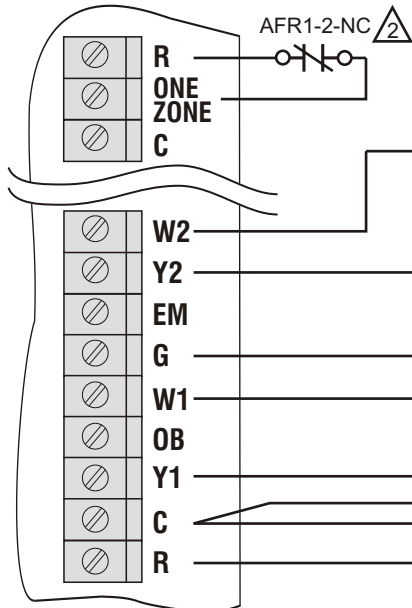
**FIGURE 1: CARRIER THERMIDISTAT - CONFIGURED AS 2 STAGE HEAT, 1 STAGE COOL(NON-HEATPUMP) WIRED TO ZONE 1 ON UZC-3C**

EQUIPMENT SELECTION	1 SPEED COOLING	2 SPEED COOLING	1 SPEED HEATPUMP	2 SPEED HEATPUMP
THERMOSTAT CONNECTIONS	FIGURE 1	FIGURE 2	FIGURE 3	FIGURE 4
FK/FV SERIES FAN COIL	FIGURE 5	FIGURE 6	FIGURE 7	FIGURE 8
VARIABLE-SPEED 2 STAGE NON-CONDENSING FURNACE	FIGURE 9	FIGURE 10	FIGURE 11	FIGURE 12
VARIABLE-SPEED 2-STAGE CONDENSING FURNACE WITHOUT DE CONNECTION	FIGURE 13	FIGURE 14	FIGURE 15	FIGURE 16
VARIABLE-SPEED 2-STAGE CONDENSING FURNACE WITH DE CONNECTION	FIGURE 17	FIGURE 18	FIGURE 19	FIGURE 20

- △1 AFR1 - DPDT RELAY W/ 24VAC COIL
- △2 OPTIONAL - ENERGIZES PANEL TO ONE ZONE MODE SO ALL ZONES GAIN DEHUMIDIFICATION WHEN CALLED
- △3 RELAY REQUIRED IF EMERGENCY HEAT ACTIVATION IS DESIRED THROUGH THERMIDISTAT, OTHERWISE USE EMERGENCY HEAT SWITCH ON THE UZC-3 CONTROL
- △4 RECOMMENDED DIP SWITCH SETTINGS FOR PARTICULAR APPLICATION. \* INDICATES REQUIRED SETTING
- △5 DO NOT CONNECT EQUIPMENT COMMON ('COM' or 'C') TO NCM-300
- △6 NO JUMPER REQUIRED IF 'RC/RH' LINK IS NOT CUT
- △7 OUTDOOR BULB THERMOSTAT 35F -- SPDT
- △8 SUPPLY MOUNTED BONNET THERMOSTAT 140F
- △9 REFER TO CARRIER INSTALLATION INSTRUCTION FOR DETAILS ON SETTING UP DEHUMIDIFICATION
- △10 FOSSIL FUEL KITS CAN BE USED IN PLACE OF OUTDOOR T'STAT AND BONNET T'STAT CONTACT TECHNICAL SUPPORT FOR INFORMATION
- △11 OUTDOOR BULB THERMOSTAT 35F -- SPDT
- △12 SUPPLY MOUNTED BONNET THERMOSTAT 140F

 <b>Englishtown, NJ 07726</b>	DWN ENG: <b>EDK</b>	DWG NAME: <b>UZC-3C DEHUMIDIFICATION W/ CARRIER THERMIDISTAT</b>	
	SIZE: <b>A</b>	DATE: <b>3/4/04</b>	DWG NO: <b>090512A0027</b>
	SCALE: NOT TO SCALE	COPYRIGHT © EWC CONTROLS INC. ALL RIGHTS RESERVED	REV: <b>C</b>

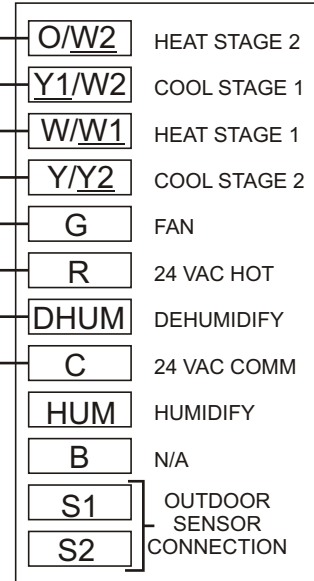
UZY-3C  
ONE-ZONE  
MODE INPUT



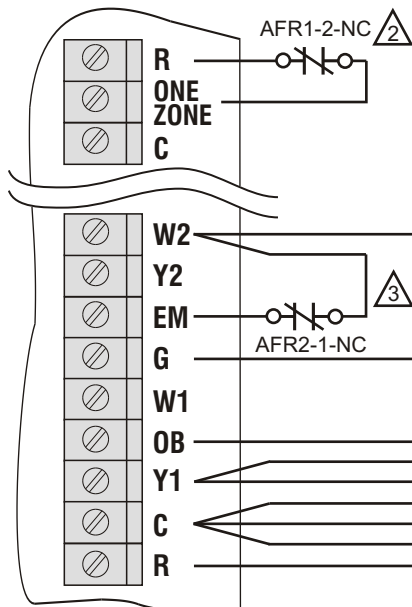
UZY-3C  
ZONE 1 T'STAT  
INPUT

**FIGURE 2:** CARRIER THERMIDISTAT - CONFIGURED AS 2 STAGE HEAT, 2 STAGE COOL(NON-HEATPUMP) WIRED TO ZONE 1 ON UZY-3C

CARRIER  
THERMIDISTAT



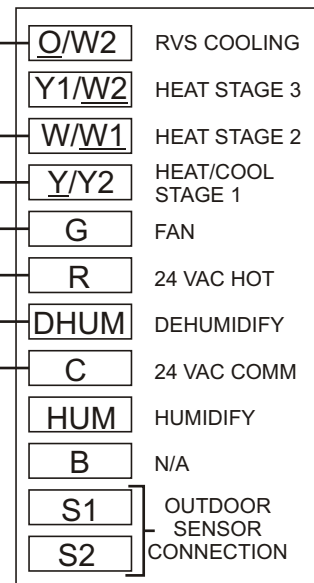
UZY-3C  
ONE-ZONE  
MODE INPUT



UZY-3C  
ZONE 1 T'STAT  
INPUT

**FIGURE 3:** CARRIER THERMIDISTAT - CONFIGURED AS 1 STAGE COMPRESSOR HEATPUMP WIRED TO ZONE 1 ON UZY-3C

CARRIER  
THERMIDISTAT



**CONTROLS INC.**  
Englishtown, NJ 07726

DWN ENG: EDK

DWG NAME: UZY-3C DEHUMIDIFICATION  
W/ CARRIER THERMIDISTAT

SIZE: A DATE: 3/4/04

DWG NO: 090512A0027

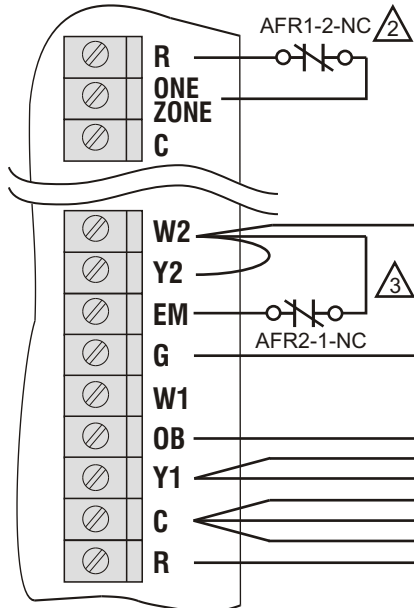
REV: C

SCALE: NOT TO SCALE

COPYRIGHT © EWC CONTROLS INC.  
ALL RIGHTS RESERVED

SHEET: 2 OF 11

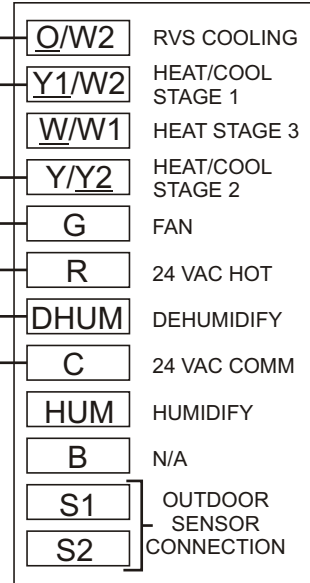
Uzc-3c  
ONE-ZONE  
MODE INPUT



Uzc-3c  
ZONE 1 T'STAT  
INPUT

**FIGURE 4:** CARRIER THERMIDISTAT - CONFIGURED AS 2 STAGE COMPRESSOR HEATPUMP WIRED TO ZONE 1 ON Uzc-3c

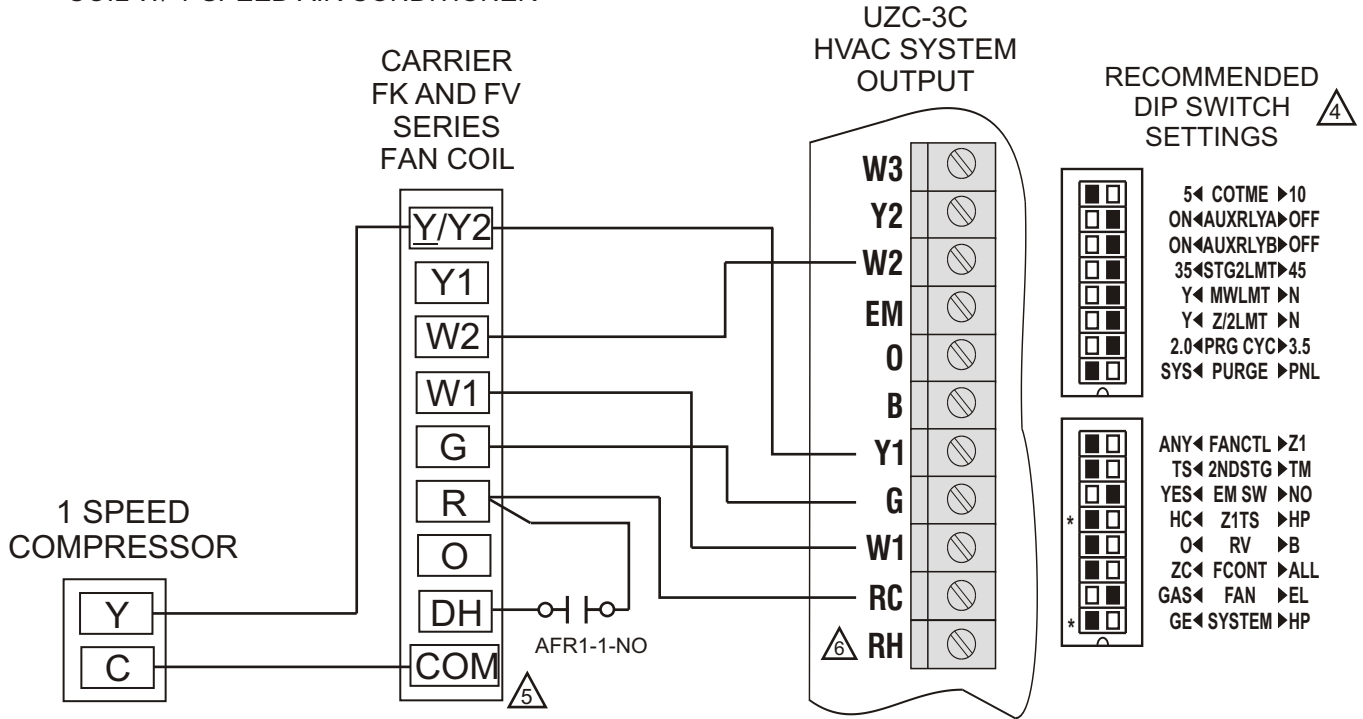
CARRIER  
THERMIDISTAT



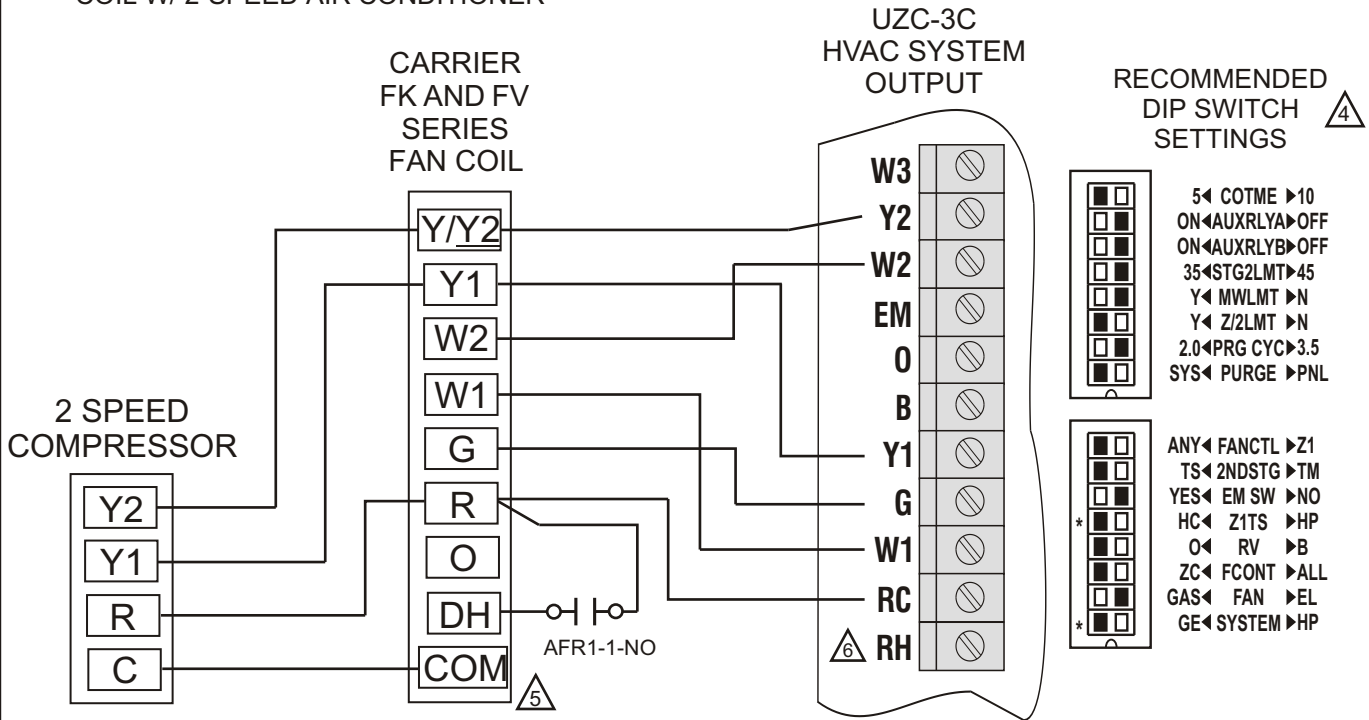
**EWC**<sup>®</sup>  
**CONTROLS INC.**  
Englishtown, NJ 07726

DWN ENG: EDK		DWG NAME: Uzc-3c DEHUMIDIFICATION W/ CARRIER THERMIDISTAT	
SIZE: A	DATE: 3/4/04	DWG NO: 090512A0027	REV: C
SCALE: NOT TO SCALE	COPYRIGHT © EWC CONTROLS INC. ALL RIGHTS RESERVED		SHEET: 3 OF 11

**FIGURE 5:** FK AND FV SERIES FAN COIL W/ 1-SPEED AIR CONDITIONER

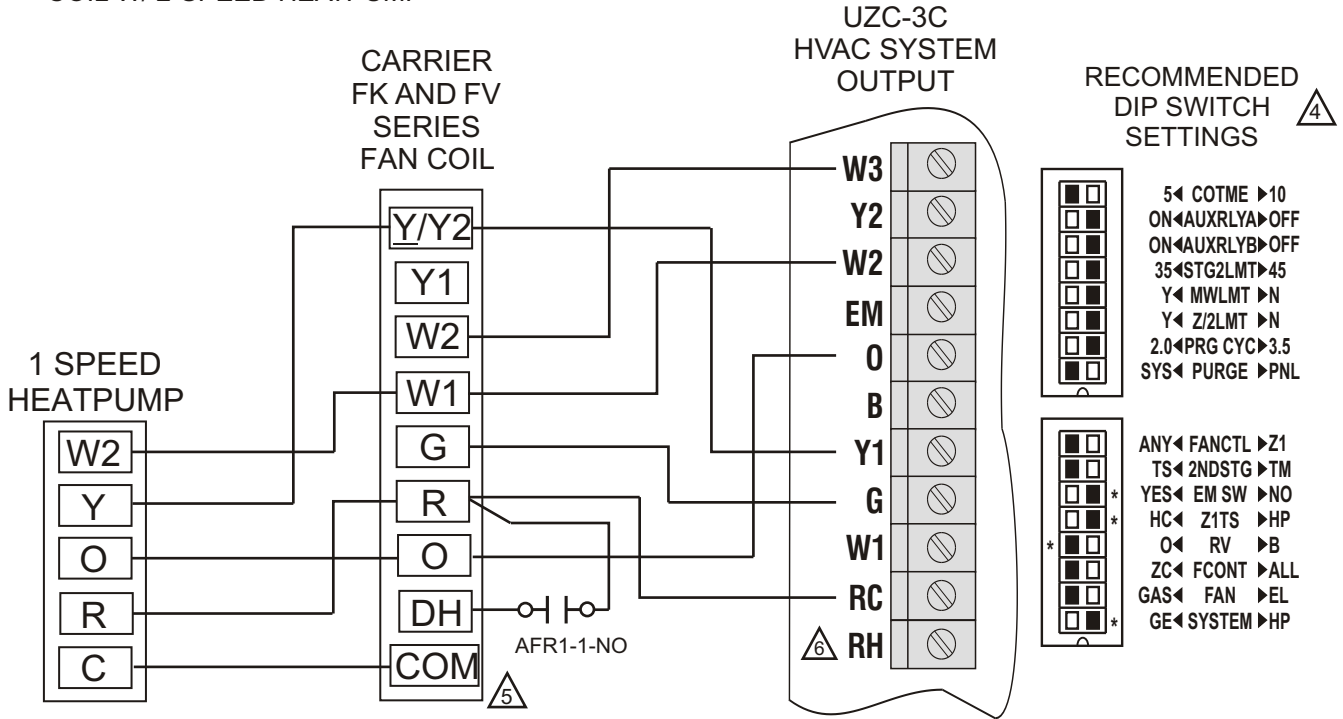


**FIGURE 6:** FK AND FV SERIES FAN COIL W/ 2-SPEED AIR CONDITIONER

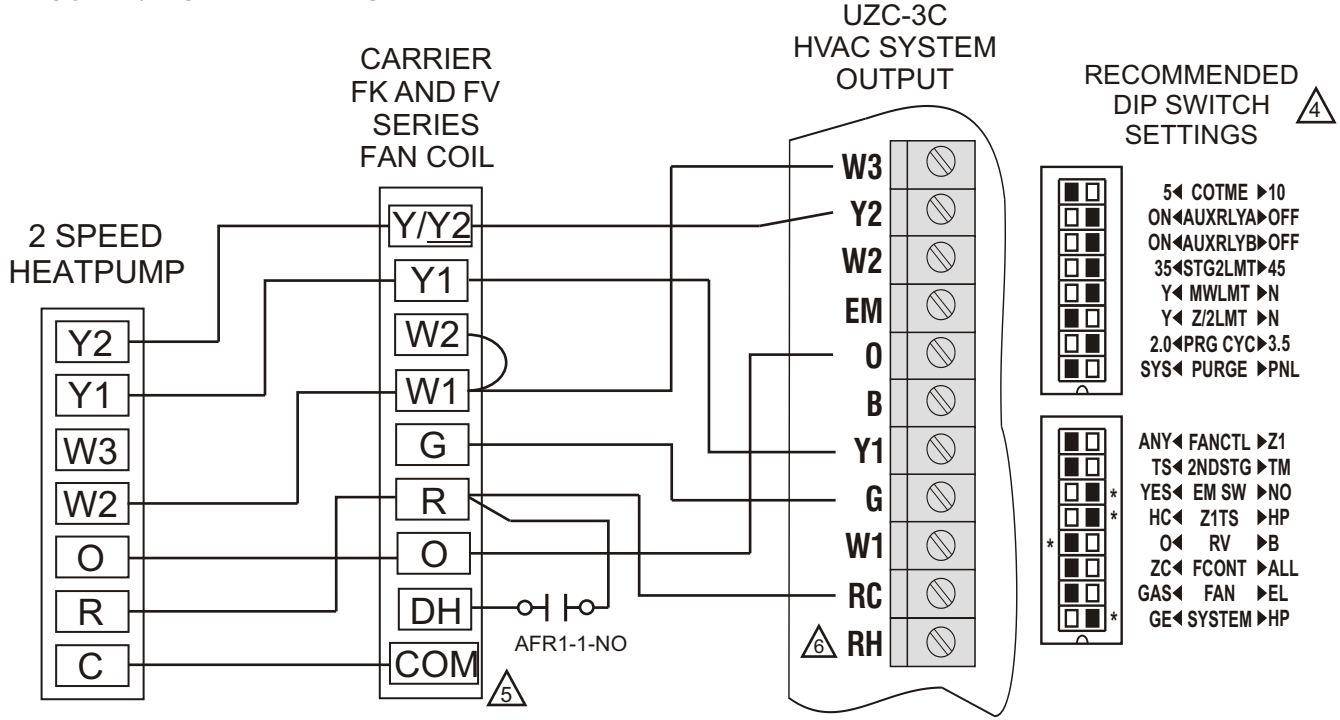


 <b>EWC</b> <sup>®</sup> <b>CONTROLS INC.</b> Englishtown, NJ 07726	DWN ENG: <b>EDK</b>	DWG NAME: <b>UZC-3C DEHUMIDIFICATION W/ CARRIER THERMIDISTAT</b>	
	SIZE: <b>A</b>	DATE: <b>3/4/04</b>	DWG NO: <b>090512A0027</b>
	SCALE: NOT TO SCALE	COPYRIGHT © EWC CONTROLS INC. ALL RIGHTS RESERVED	REV: <b>C</b>

**FIGURE 7:** FK AND FV SERIES FAN COIL W/ 2-SPEED HEATPUMP

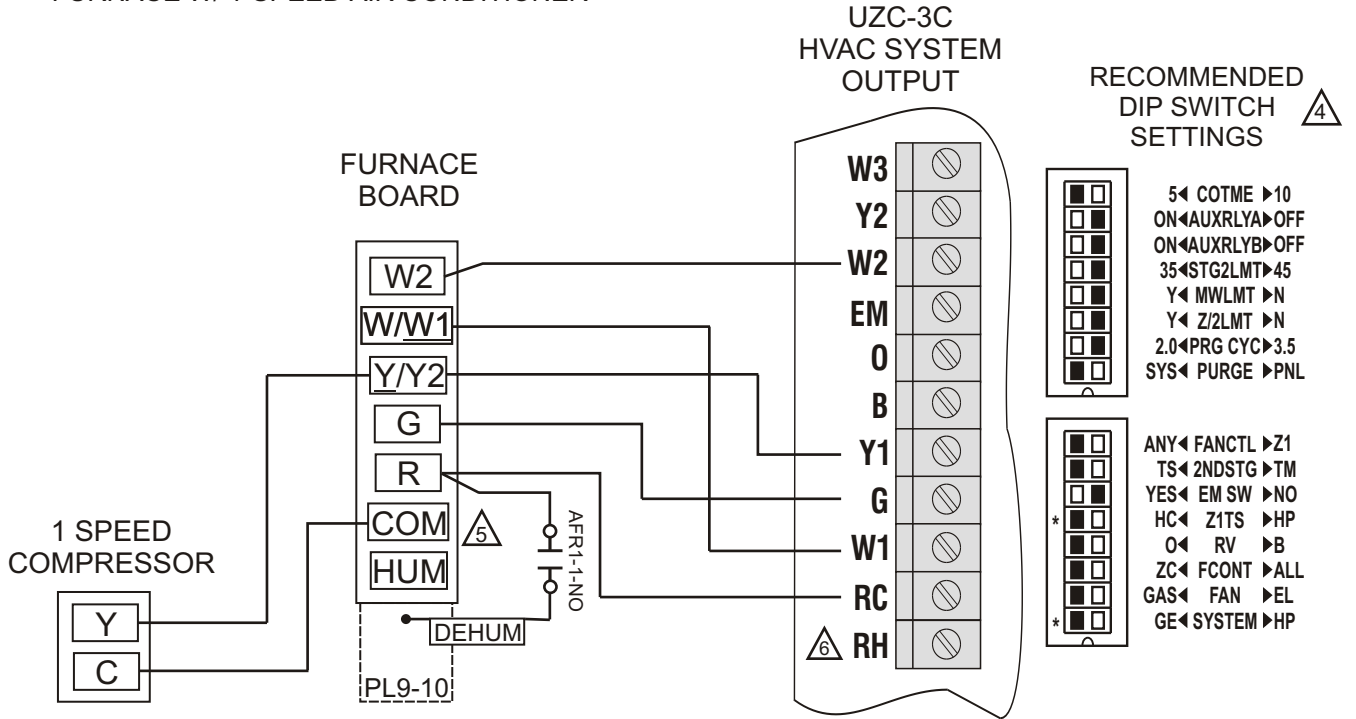


**FIGURE 8:** FK AND FV SERIES FAN COIL W/ 2-SPEED HEATPUMP

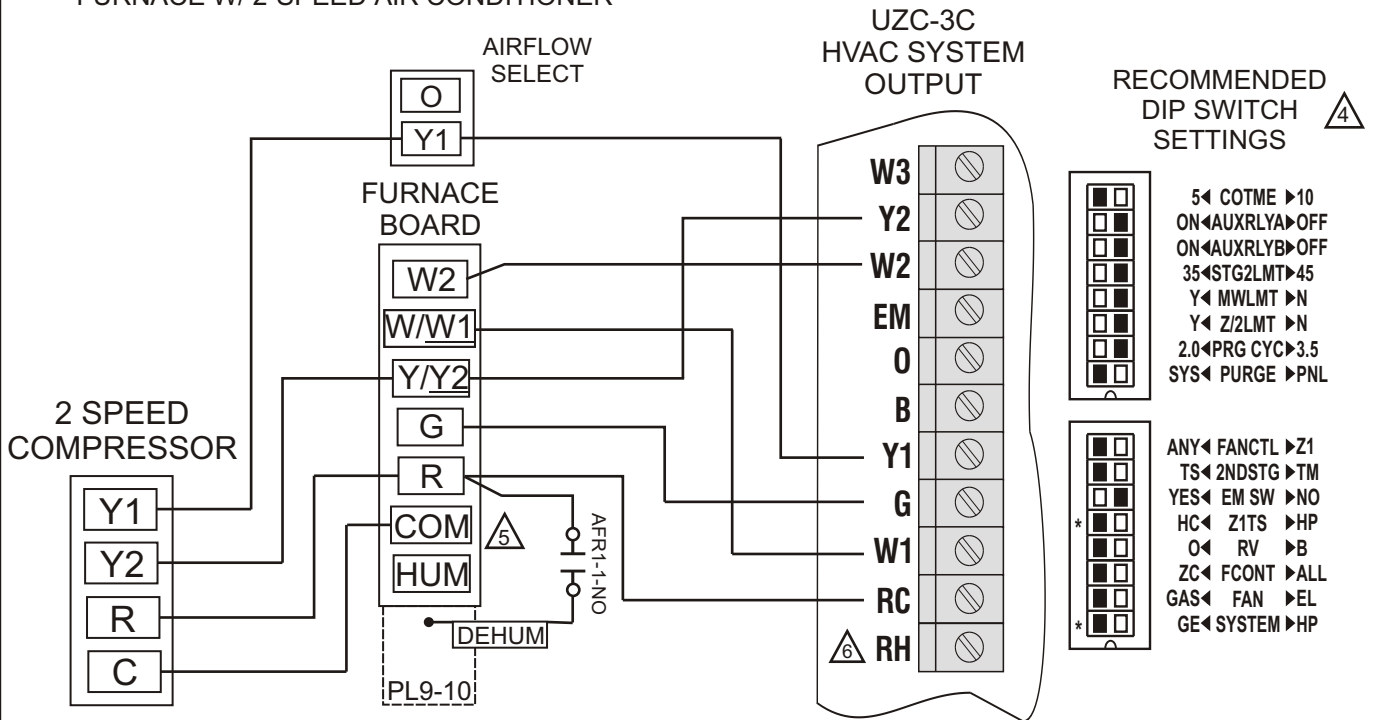


<p><b>EWC</b><sup>®</sup>  <b>CONTROLS INC.</b>      Englishtown, NJ 07726</p>	DWN ENG: <b>EDK</b>	DWG NAME: <b>UZC-3C DEHUMIDIFICATION W/ CARRIER THERMIDISTAT</b>		
	SIZE: <b>A</b>	DATE: <b>3/4/04</b>	DWG NO: <b>090512A0027</b>	REV: <b>C</b>
	SCALE: NOT TO SCALE	COPYRIGHT © EWC CONTROLS INC. ALL RIGHTS RESERVED		SHEET: <b>5 OF 11</b>

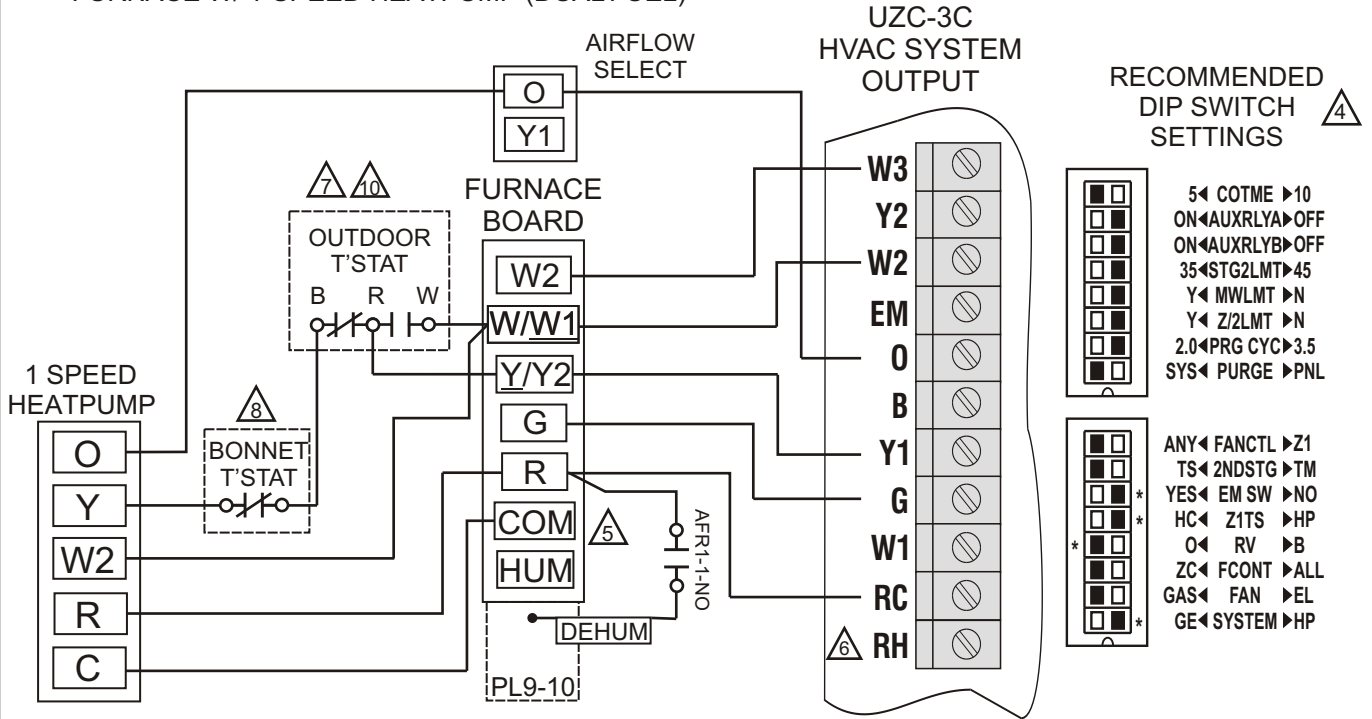
**FIGURE 9:** VARIABLE-SPEED 2-STAGE NON-CONDENSING FURNACE W/ 1-SPEED AIR CONDITIONER



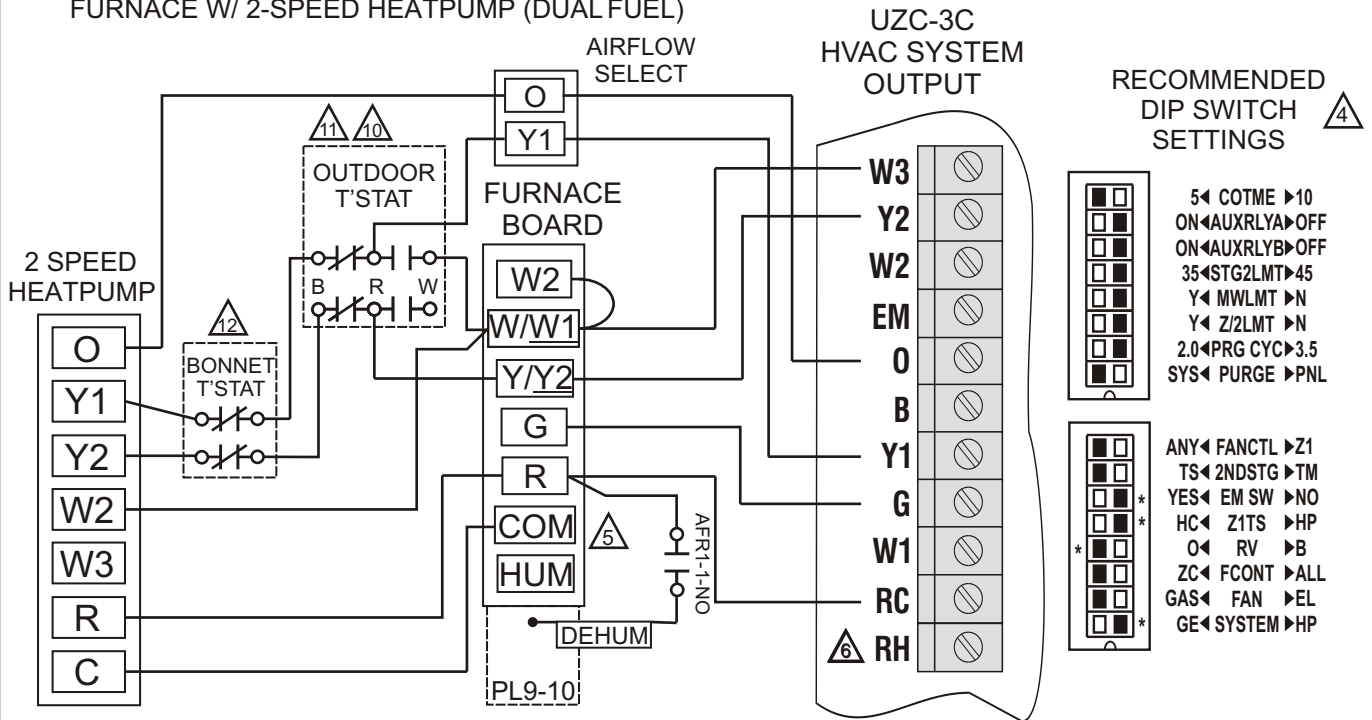
**FIGURE 10:** VARIABLE-SPEED 2-STAGE NON-CONDENSING FURNACE W/ 2-SPEED AIR CONDITIONER



**FIGURE 11:** VARIABLE-SPEED 2-STAGE NON-CONDENSING FURNACE W/ 1-SPEED HEATPUMP (DUAL FUEL)

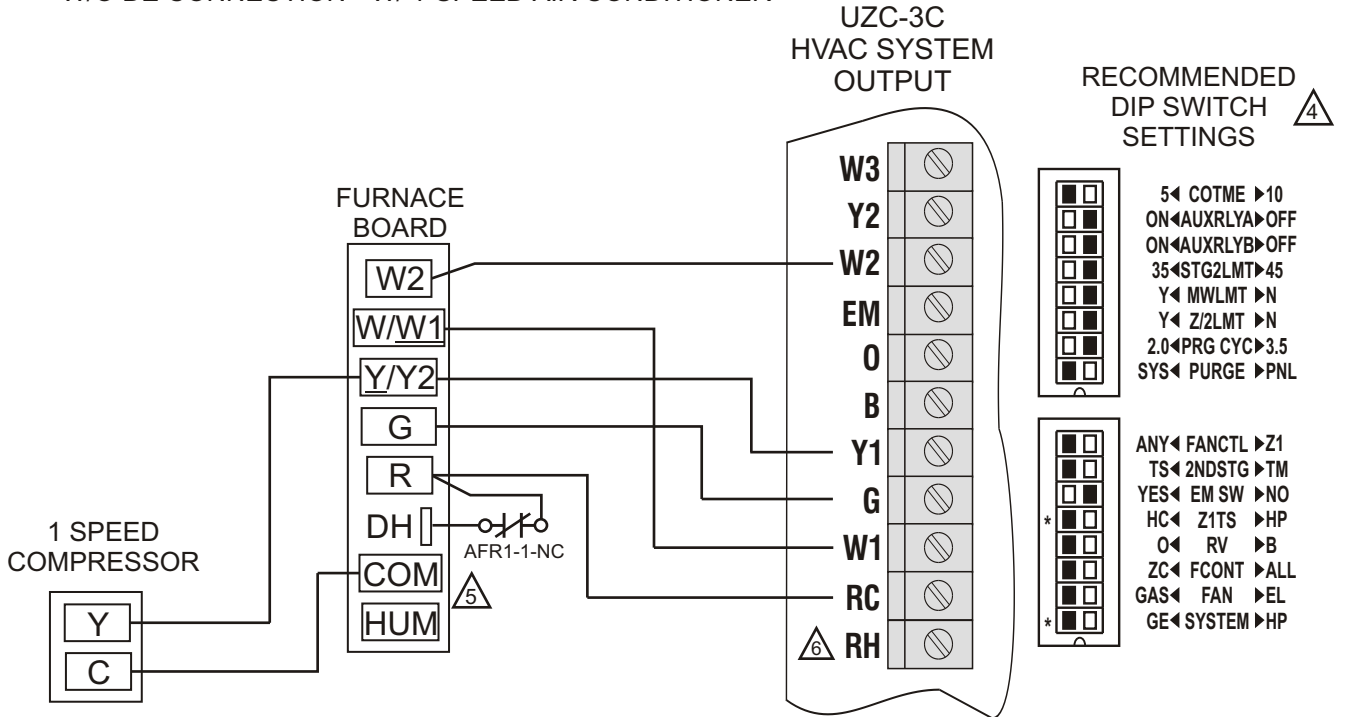


**FIGURE 12:** VARIABLE-SPEED 2-STAGE NON-CONDENSING FURNACE W/ 2-SPEED HEATPUMP (DUAL FUEL)

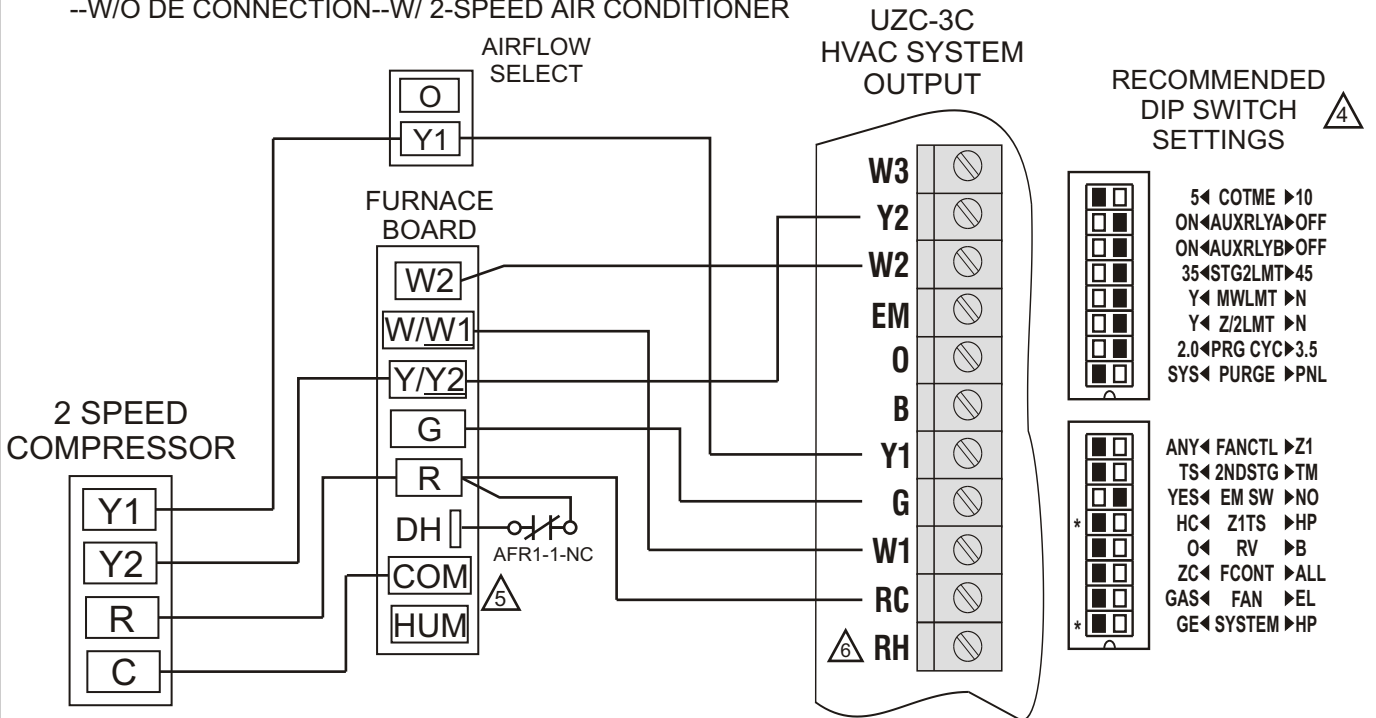


<p><b>EWC</b><sup>®</sup> CONTROLS INC. Englishtown, NJ 07726</p>	DWN ENG: EDK	DWG NAME: UZC-3C DEHUMIDIFICATION W/ CARRIER THERMIDISTAT		
	SIZE: A	DATE: 3/4/04	DWG NO: 090512A0027	
	SCALE: NOT TO SCALE	COPYRIGHT © EWC CONTROLS INC. ALL RIGHTS RESERVED	SHEET: 7 OF 11	REV: C

**FIGURE 13:** VARIABLE-SPEED 2-STAGE CONDENSING FURNACE  
 --W/O DE CONNECTION-- W/ 1-SPEED AIR CONDITIONER



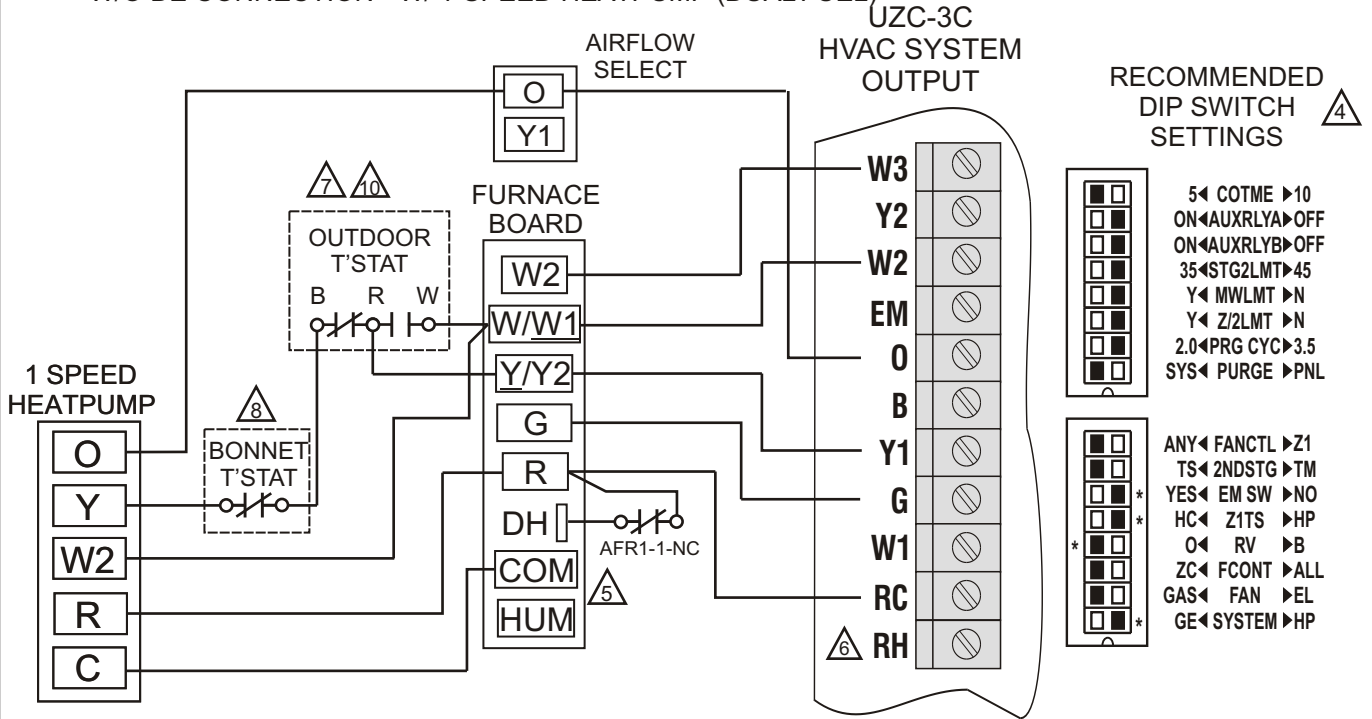
**FIGURE 14:** VARIABLE-SPEED 2-STAGE CONDENSING FURNACE  
 --W/O DE CONNECTION-- W/ 2-SPEED AIR CONDITIONER



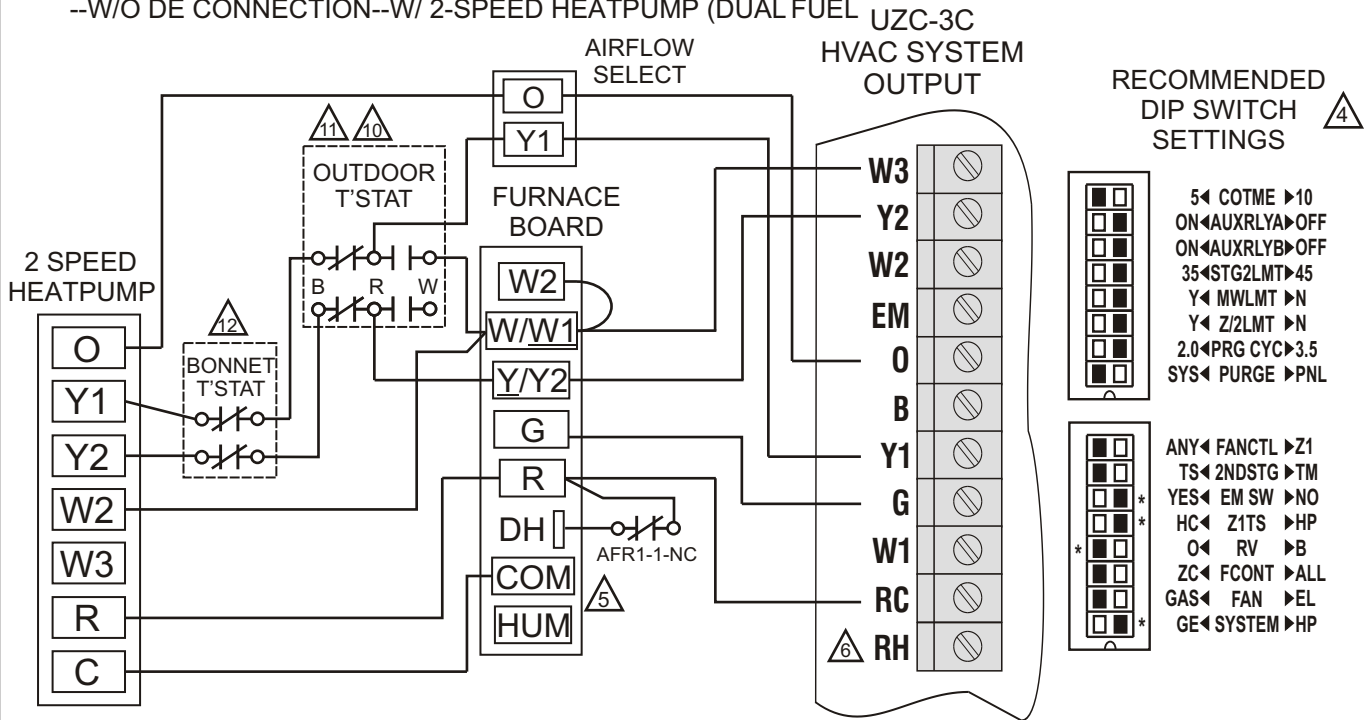
 <b>EWC</b> <sup>®</sup> <b>CONTROLS INC.</b> Englishtown, NJ 07726	DWN ENG:	EDK	DWG NAME:	UZC-3C DEHUMIDIFICATION W/ CARRIER THERMIDISTAT		
	SIZE:	A	DATE:	3/4/04	DWG NO:	090512A0027
	SCALE:	NOT TO SCALE	COPYRIGHT © EWC CONTROLS INC.	ALL RIGHTS RESERVED	SHEET:	8 OF 11
				REV:	C	



**FIGURE 15: VARIABLE-SPEED 2-STAGE CONDENSING FURNACE**  
 --W/O DE CONNECTION-- W/ 1-SPEED HEATPUMP (DUAL FUEL)



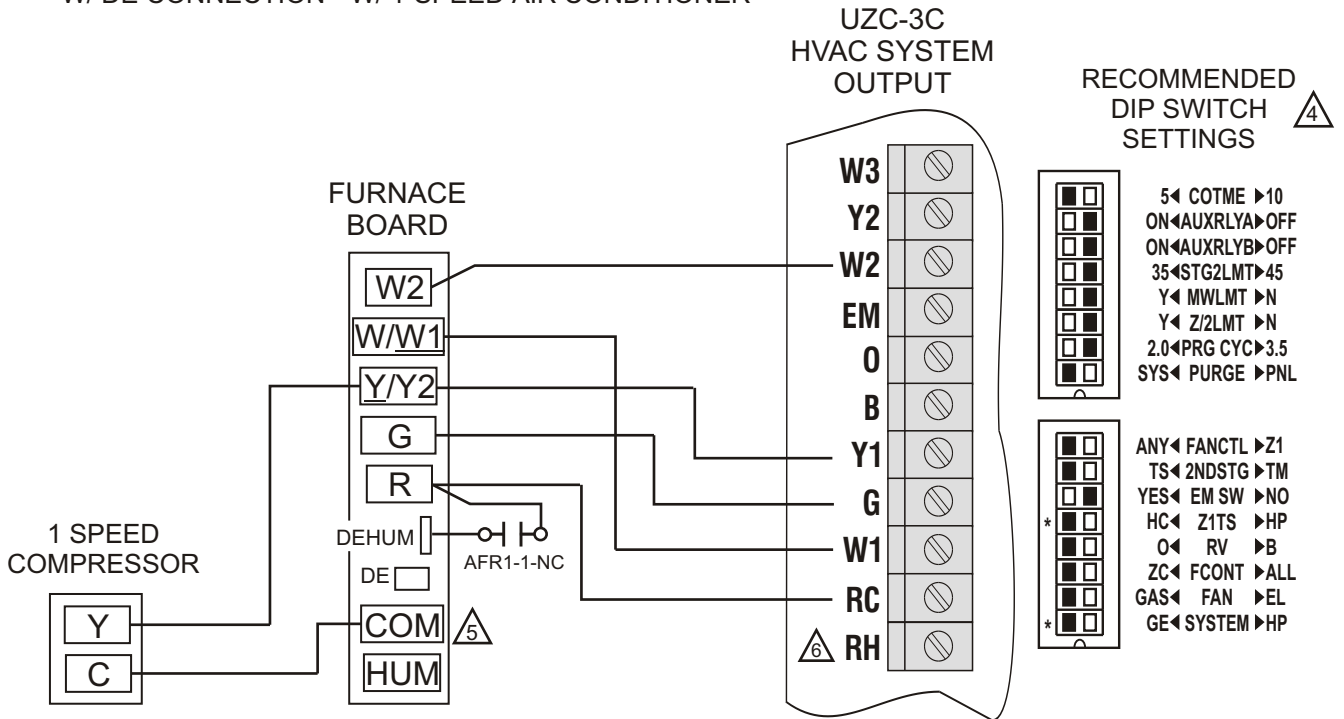
**FIGURE 16: VARIABLE-SPEED 2-STAGE CONDENSING FURNACE**  
 --W/O DE CONNECTION-- W/ 2-SPEED HEATPUMP (DUAL FUEL)



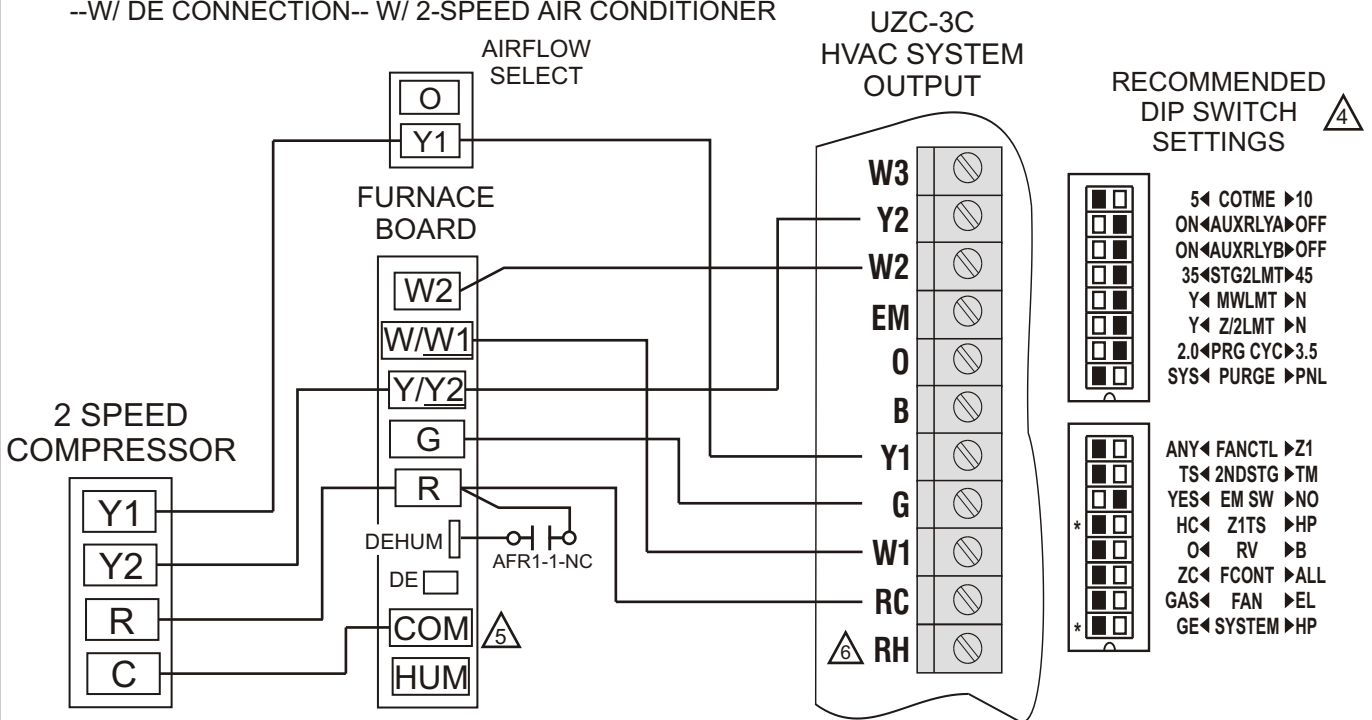
**EWC**<sup>®</sup>  
**CONTROLS INC.**  
 Englishtown, NJ 07726

DWN ENG: EDK		DWG NAME: UZC-3C DEHUMIDIFICATION W/ CARRIER THERMIDISTAT	
SIZE: A	DATE: 3/4/04	DWG NO: 090512A0027	REV: C
SCALE: NOT TO SCALE	COPYRIGHT © EWC CONTROLS INC. ALL RIGHTS RESERVED		SHEET: 9 OF 11

**FIGURE 17:** VARIABLE-SPEED 2-STAGE CONDENSING FURNACE  
 --W/ DE CONNECTION-- W/ 1-SPEED AIR CONDITIONER

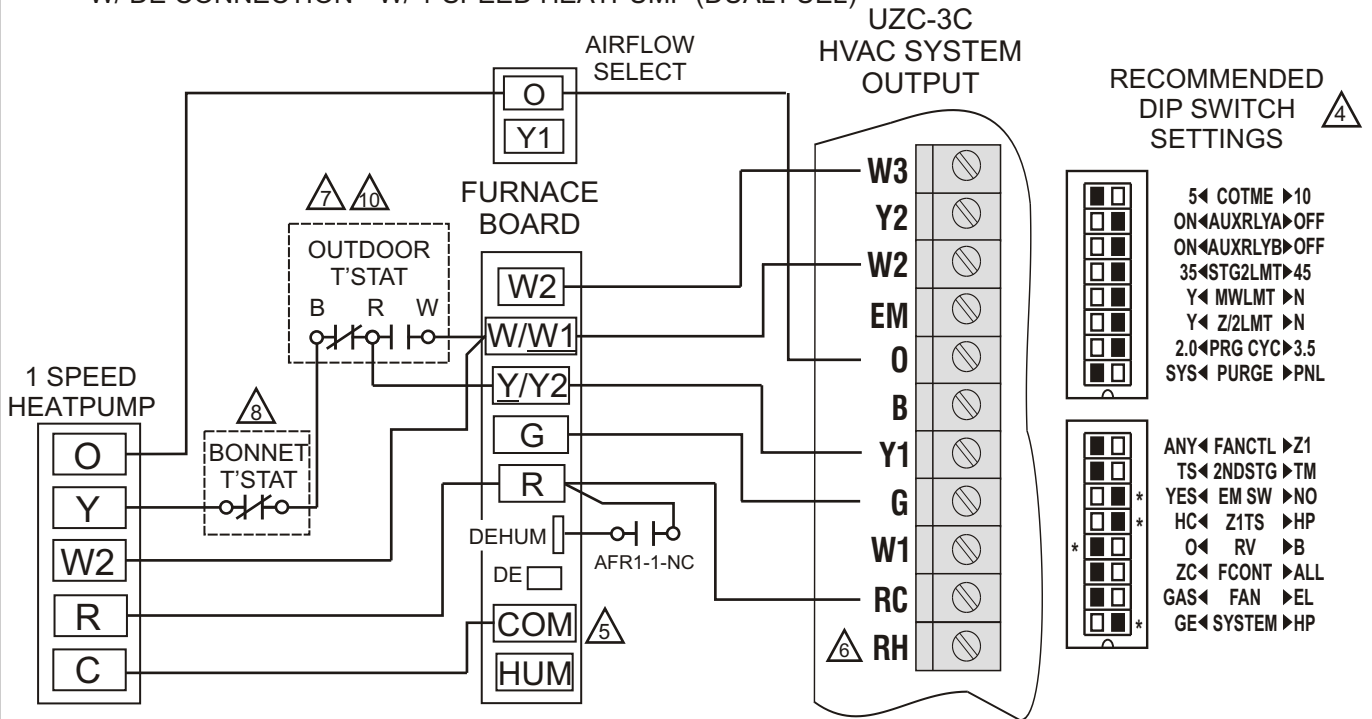


**FIGURE 18:** VARIABLE-SPEED 2-STAGE CONDENSING FURNACE  
 --W/ DE CONNECTION-- W/ 2-SPEED AIR CONDITIONER



<p><b>EWC</b><sup>®</sup>  <b>CONTROLS INC.</b>          Englishtown, NJ 07726</p>	DWN ENG:	EDK	DWG NAME:	UZC-3C DEHUMIDIFICATION W/ CARRIER THERMIDISTAT		
	SIZE:	A	DATE:	3/4/04	DWG NO:	090512A0027
	SCALE:	NOT TO SCALE	COPYRIGHT © EWC CONTROLS INC.	ALL RIGHTS RESERVED	SHEET:	10 OF 11
	REV:	C				

**FIGURE 19:** VARIABLE-SPEED 2-STAGE CONDENSING FURNACE  
 --W/ DE CONNECTION-- W/ 1-SPEED HEATPUMP (DUAL FUEL)



**FIGURE 20:** VARIABLE-SPEED 2-STAGE CONDENSING FURNACE  
 --W/ DE CONNECTION-- W/ 2-SPEED HEATPUMP (DUAL FUEL)

