

WIRING DIAGRAM

NCM-300
HVAC SYSTEM
OUTPUT

HEATPUMP
OUTDOOR UNIT

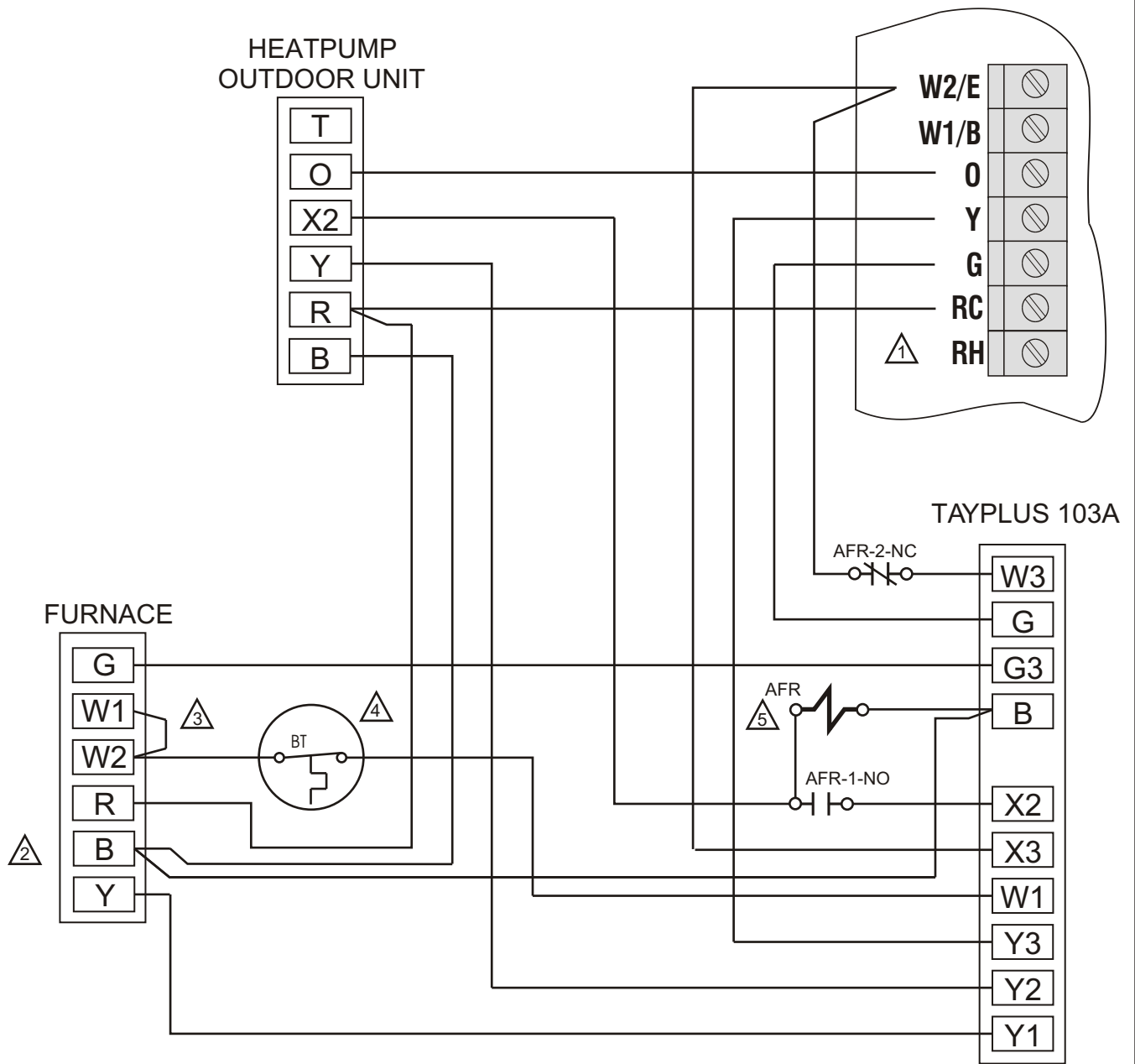

△1 NO JUMPER REQUIRED IF RC/RH LINK IS NOT CUT

△2 DO NOT CONNECT 'B' TO NCM-300

△3 THIS JUMPER REQUIRED ONLY FOR 2 STAGE FURNACE APPLICATIONS

△4 BONNET THERMOSTAT MODEL TAYPLUS101A REQUIRED FOR OIL FURNACE APPLICATIONS

△5 AFR = DPDT RELAY W/ 24VAC COIL

<p>EWC[®] CONTROLS INC. Englishtown, NJ 07726</p>	DWN ENG: EDK		DWG NAME: NCM-300 DUAL FUEL W/ TAYPLUS 103A--NON-RESTRICTED	
	SIZE: A	DATE: 12/01/03	DWG NO: 090512A0005	REV: C
	SCALE: NOT TO SCALE	COPYRIGHT © EWC CONTROLS INC. ALL RIGHTS RESERVED		SHEET: 1 OF 1