

# ULTRA-ZONE™

Forced Air Zone Controls

# TECHNICAL BULLETIN

**Model MCS-DXB**  
 Remote Selector Switch for all "ST" series  
 Zone Control Panels.

\*Includes 2x4 junction box and hardware.

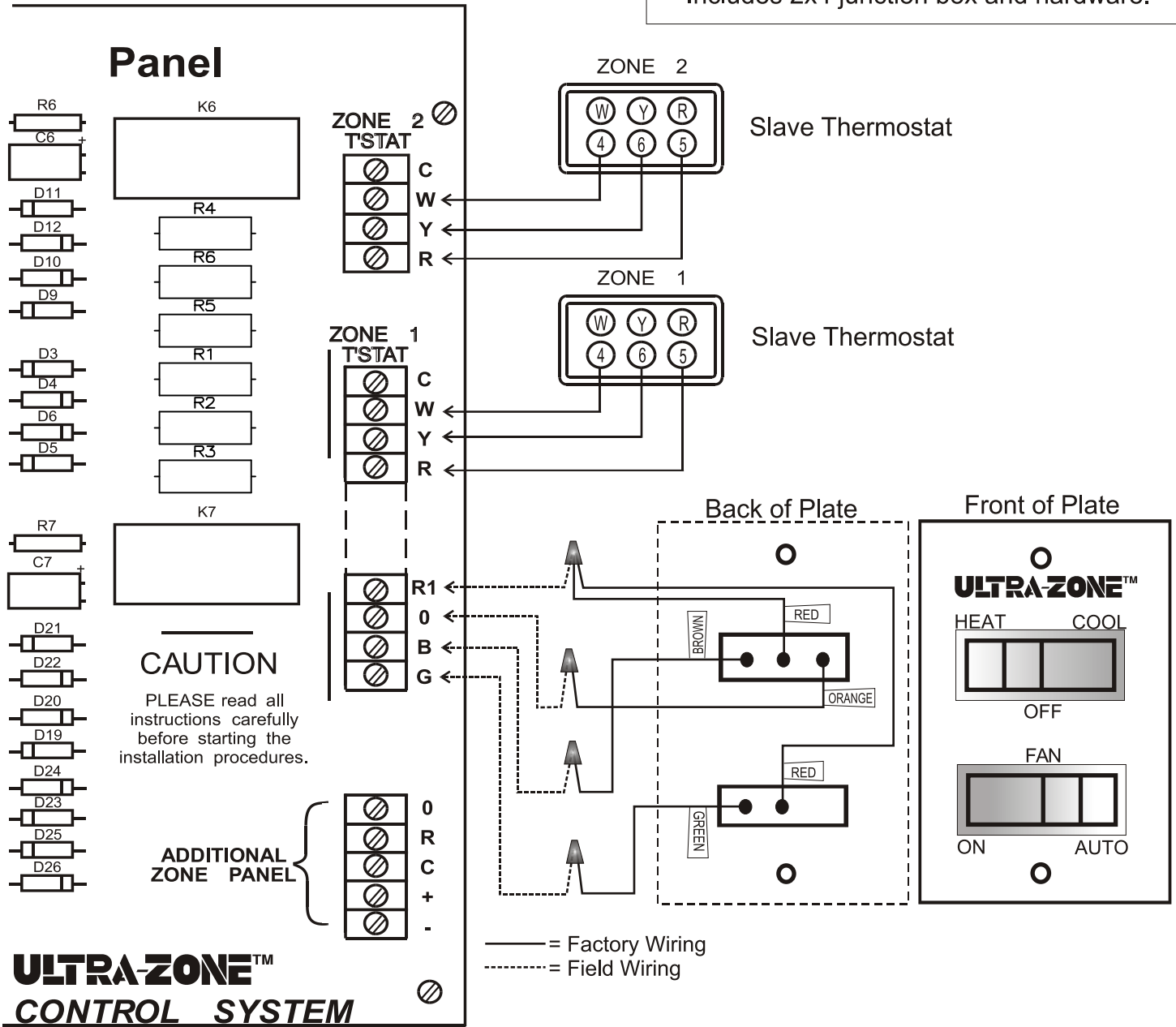

Follow the color coded wiring diagram to achieve manual changeover control of the HVAC system from Heating mode to Cooling mode. You can also achieve manual control of the system Fan operation. **Use 24vac only. Follow national and local electrical codes and ordinances.**

Excellence Without Compromise



**EWC CONTROLS, LLC.** 385 Hwy. 33 Englishtown, NJ 07726  
 Ph: 800-446-3110 - Fx: 732-446-5362