

WIRING DIAGRAM

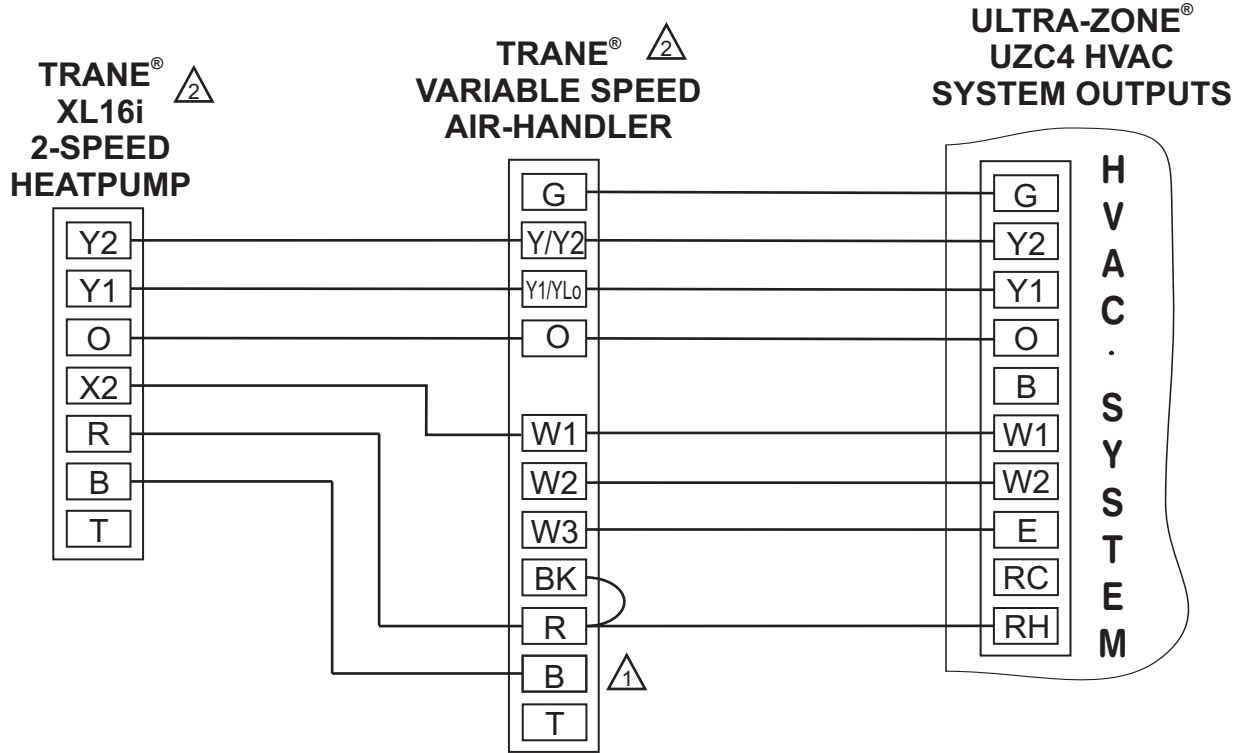

⚠ DO NOT CONNECT EQUIPMENT 24vac COMMON 'B' TERMINAL TO UZC4 PANEL

⚠ REFER TO YOUR TRANE INSTALLER'S GUIDE FOR FURTHER INFORMATION

EWC®

CONTROLS INC.

Englishtown, NJ 07726

DRAWING BY:
PJC

DWG NAME: UZC4 -- W/ TRANE XL16i HEATPUMP

DATE:
02/25/10

SIZE:
A

REV:
B

DWG NO:
090512A0137

SHEET: 1 OF 1

COPYRIGHT © EWC CONTROLS INC.
ALL RIGHTS RESERVED

DISCLAIMER: EWC Controls Inc., Cannot be held liable for the use or misuse of this supplied information. It is the responsibility of the user to determine the suitability of the application. Malfunctions, improper operation, and/or subsequent damage to any related equipment or property damage as a result of using this supplied information is the responsibility of the user. EWC Controls Inc., is not responsible for any misapplications including, but not limited to negligence, defect in product(s), system incompatibility, poor workmanship and/or installation.