

WIRING DIAGRAM

*CREATED FOR WEC HEATING & A/C

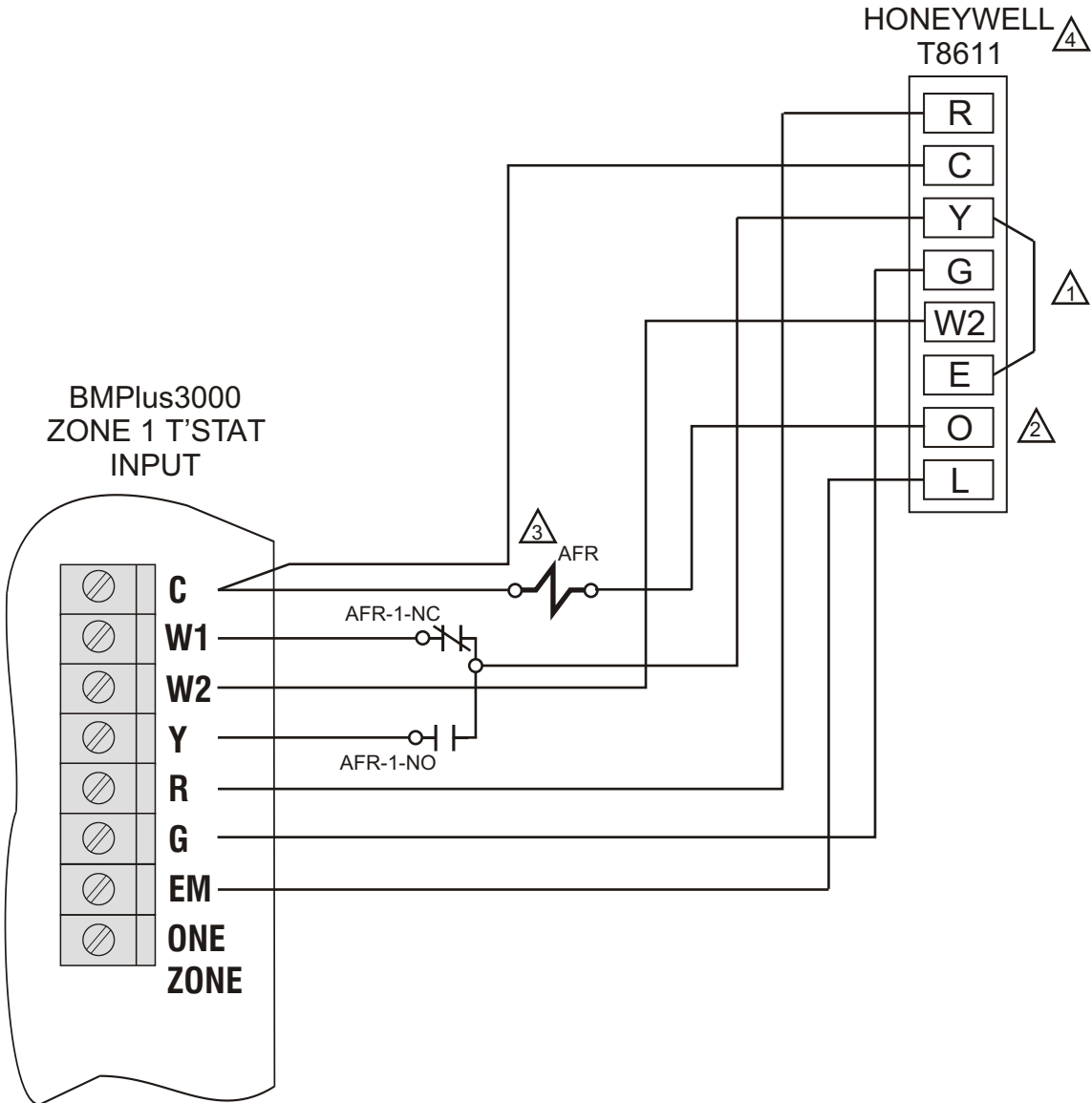

- ⚠️ 1 JUMPER REQUIRED FOR EMERGENCY HEAT
- ⚠️ 2 'O/B' SWITCH TO BE IN 'O' POSITION
- ⚠️ 3 AFR - SPDT RELAY W/ 24VAC COIL
- ⚠️ 4 HONEYWELL T8611 -- OEM VERSION W/ CONSTANT 'L' OUTPUT ON EMERGENCY DEMANDS



CONTROLS INC.

Englishtown, NJ 07726

DRAWING BY:
EDK

DWG NAME: BMPlus3000 THERMOSTAT WIRING
W/ T8611 -- OEM THERMOSTAT

DATE:
11/04/04

SIZE:
A

REV:
A

DWG NO:
090512A0085

SHEET: 1 OF 1

COPYRIGHT © EWC CONTROLS INC.
ALL RIGHTS RESERVED

DISCLAIMER: EWC Controls Inc., Cannot be held liable for the use or misuse of this supplied information. It is the responsibility of the user to determine the suitability of the application. Malfunctions, improper operation, and/or subsequent damage to any related equipment or property damage as a result of using this supplied information is the responsibility of the user. EWC Controls Inc., is not responsible for any misapplications including, but not limited to negligence, defect in products(s), system incompatibility, poor workmanship and/or installation.