

WIRING DIAGRAM

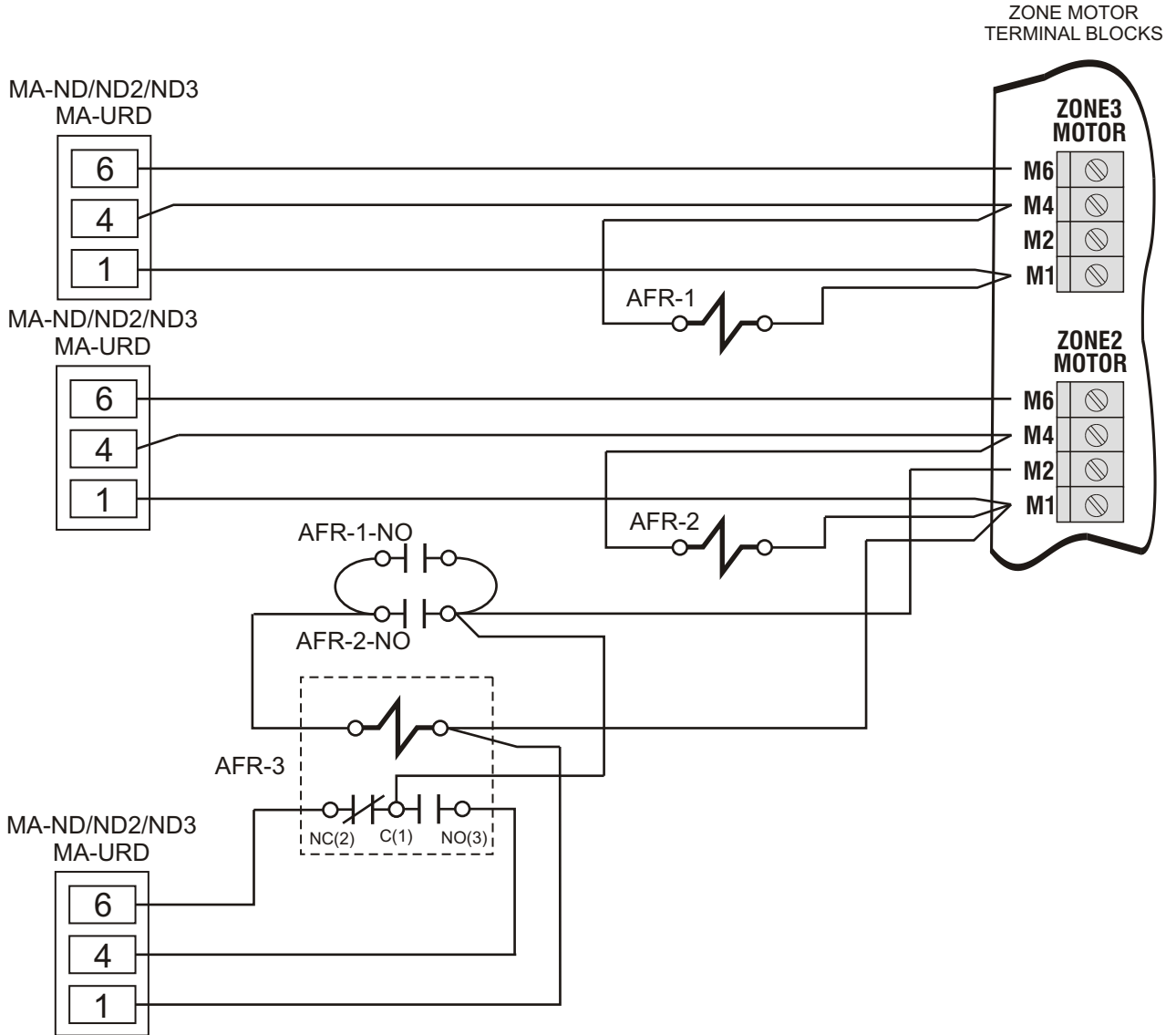

NOTE:
AFR RELAYS -- MODEL R1, SPDT RELAY W/ 24VAC COIL

EWC[®]
CONTROLS INC.

Englishtown, NJ 07726

DRAWING BY:
EDK

DWG NAME: MODEL ND/URD -- ADDITIONAL DAMPER
WIRED FOR ZONES 2 & 3

DATE:
11/29/04

SIZE:
A

REV:
A

DWG NO:
090512A0050

SHEET: 1 OF 1

COPYRIGHT © EWC CONTROLS INC.
ALL RIGHTS RESERVED

DISCLAIMER: EWC Controls Inc., Cannot be held liable for the use or misuse of this supplied information. It is the responsibility of the user to determine the suitability of the application. Malfunctions, improper operation, and/or subsequent damage to any related equipment or property damage as a result of using this supplied information is the responsibility of the user. EWC Controls Inc., is not responsible for any misapplications including, but not limited to negligence, defect in products(s), system incompatibility, poor workmanship and/or installation.