

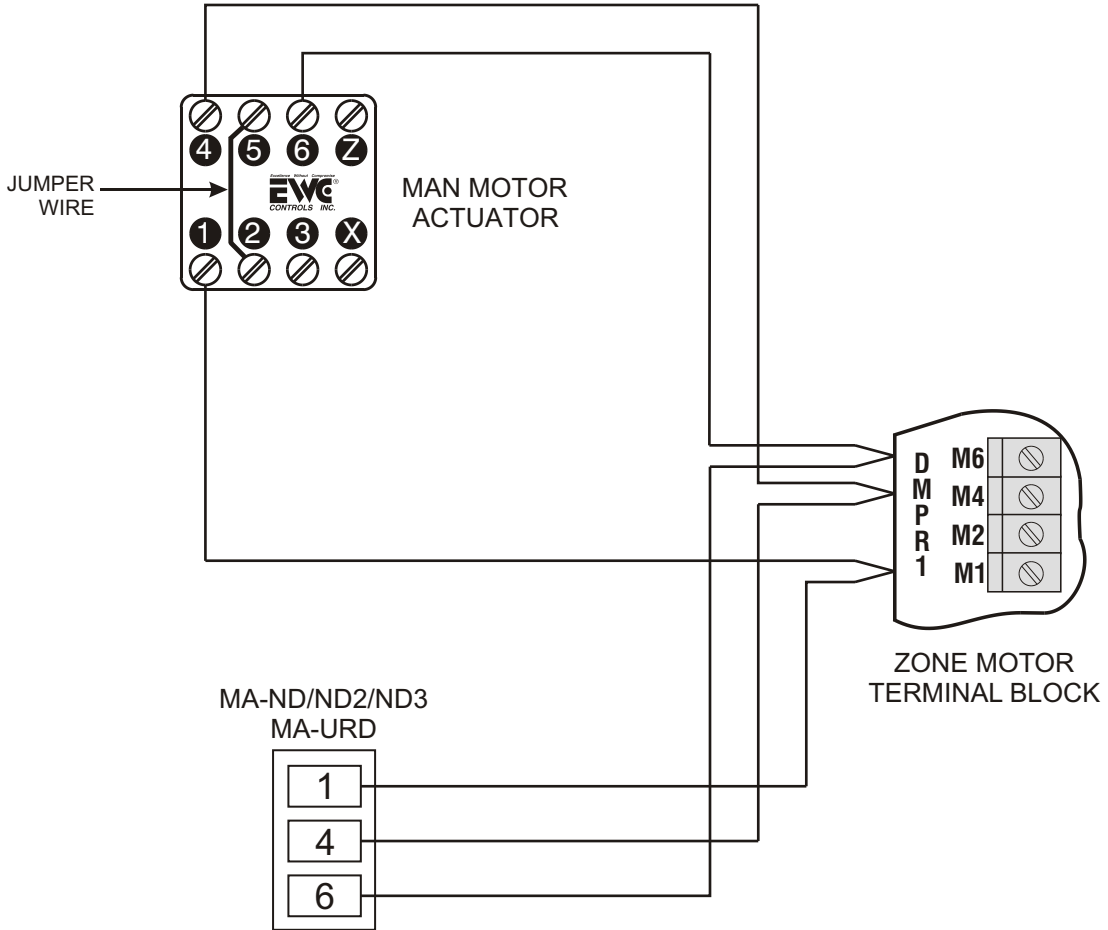

WIRING DIAGRAM



*WHEN WIRED AS SHOWN "SMD" DAMPER WILL OPEN OR CLOSE FIRST THEN THE "ND/URD" DAMPER WILL OPEN OR CLOSE

 EWC [®] CONTROLS INC. Englishtown, NJ 07726	DWN ENG: EDK		DWG NAME: MODEL ND/URD DAMPER WIRED WITH MODEL SMD STYLE DAMPER	
	SIZE: A	DATE: 01/27/03	DWG NO: 090512A0047	REV: A
	SCALE: NOT TO SCALE	COPYRIGHT © EWC CONTROLS INC. ALL RIGHTS RESERVED		SHEET: 1 OF 1