

WIRING DIAGRAM

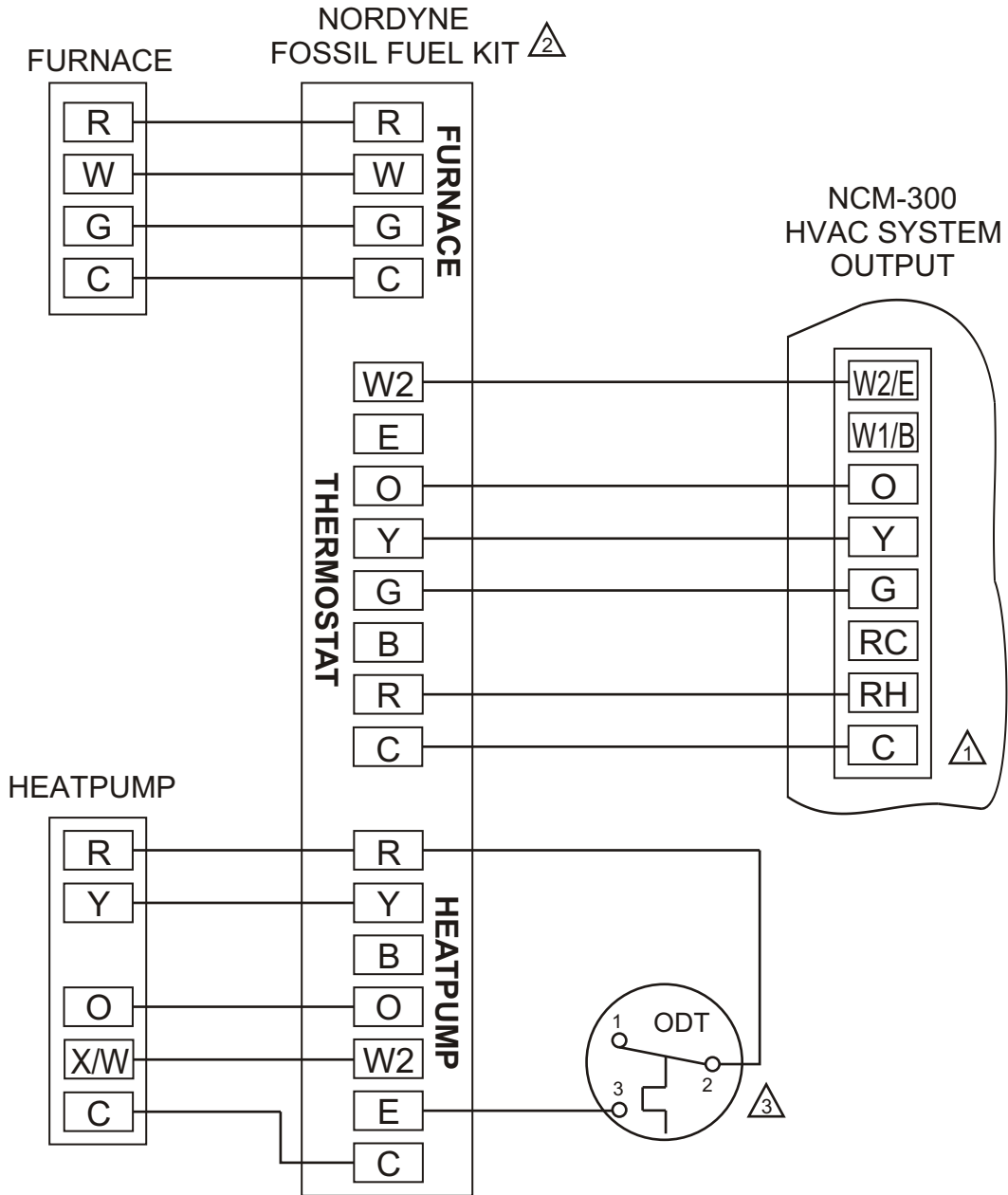

△1 OLDER VERSIONS OF THE NCM-300 DO NOT HAVE A 'C' TERMINAL ON THE SYSTEM TERMINAL BLOCK. DO NOT MAKE THIS CONNECTION IF NO 'C' TERMINAL IS PRESENT.

△2 PLEASE REFER TO THE NORDYNE FOSSIL FUEL KIT MANUAL FOR MORE INFORMATION ON INSTALLATION.

△3 PLEASE REFER TO THE NORDYNE FOSSIL FUEL KIT MANUAL FOR MORE INFORMATION ON THE OUTDOOR AIR SENSOR



CONTROLS INC.

Englishtown, NJ 07726

DRAWING BY:
EDK

DWG NAME: MODEL NCM-300 -- DUAL FUEL
W/ NORDYNE FOSSIL FUEL KIT

DATE:
07/18/06

SIZE:
A

REV:
A

DWG NO:
090512A0015

SHEET: 1 OF 1

COPYRIGHT © EWC CONTROLS INC.
ALL RIGHTS RESERVED

DISCLAIMER: EWC Controls Inc., Cannot be held liable for the use or misuse of this supplied information. It is the responsibility of the user to determine the suitability of the application. Malfunctions, improper operation, and/or subsequent damage to any related equipment or property damage as a result of using this supplied information is the responsibility of the user. EWC Controls Inc., is not responsible for any misapplications including, but not limited to negligence, defect in product(s), system incompatibility, poor workmanship and/or installation.