

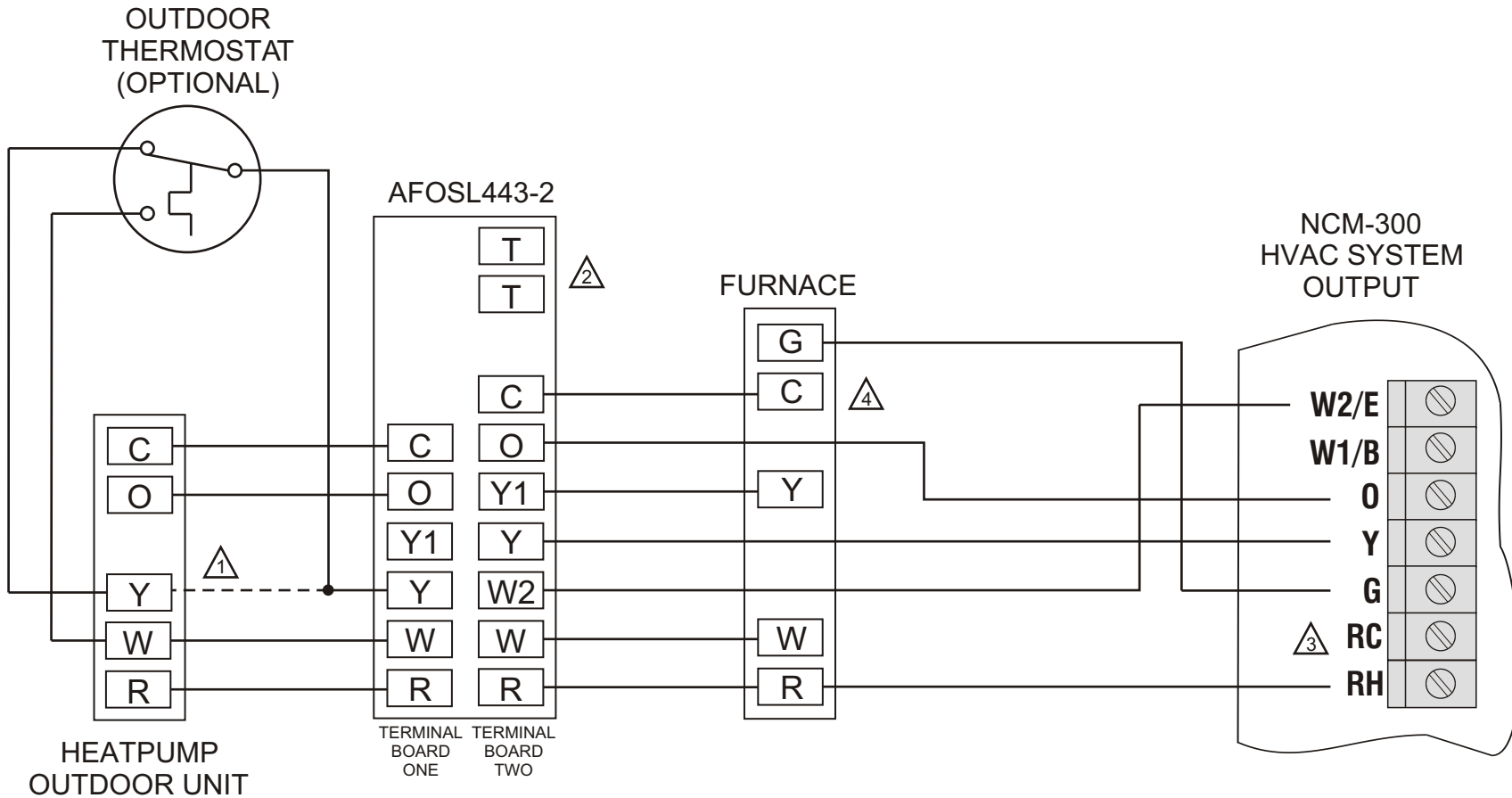

WIRING DIAGRAM



- ⚠️ IF OUTDOOR THERMOSTAT IS NOT USED, FIELD WIRE DIRECTLY FROM 'Y' TERMINAL ON OUTDOOR THERMOSTAT TO 'Y' TERMINAL ON TERMINAL BOARD ONE
- ⚠️ USE 'T' & 'T' CONNECTIONS FOR OIL BURNERS REQUIRING ISOLATED CONTACTS
- ⚠️ NO JUMPER REQUIRED IF RC/RH LINK IS NOT CUT
- ⚠️ DO NOT CONNECT 'C' TO NCM-300

 EWC [®] CONTROLS INC. Englishtown, NJ 07726	DWN ENG: EDK		DWG NAME: NCM-300 DUAL FUEL W/ AFOSL443-2 FOSSIL FUEL KIT	
	SIZE: A	DATE: 12/01/03	DWG NO: 090512A0007	REV: B
	SCALE: NOT TO SCALE	COPYRIGHT © EWC CONTROLS INC. ALL RIGHTS RESERVED		SHEET: 1 OF 1