

ULTRA-ZONE™

Forced Air Zone Controls

DATA SHEET

Model URD-LM24

The URD-LM24 series of round motorized dampers are a double layered blade design with a integrated Neoprene™ sealing gasket. The superior design insures long life and no maintenance. URD-LM24 dampers are easy to install, easy to wire up, and come with a 5 year warranty. The URD-LM24 damper is constructed of heavy gauge galvanized steel. The nylon bearings and drive shafts insure smooth, quiet operation and provides a thermal barrier to the motor. It is designed to operate at static pressures up to 2" w.c. @ < 10% leakage.

The UL Listed Motor Actuator is a 24vac 3 wire power open / power close type rated at 35 " lbs. of torque. It includes an integrated terminal block, and NEMA 1 rated housing. The motor also includes Min/Max adjustment capability to allow adjustment of the design CFM flow into a particular zone or area. A positional arrow is also included that provides visual indication of blade travel. The Damper should be installed to orient motor at any angle top or sides. Do not install with motor at bottom of the duct work.

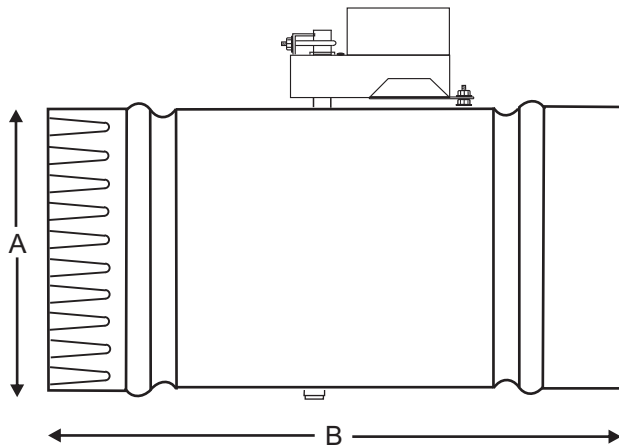

NOMINAL DIMENSIONS

DIMENSIONS		
MODEL #	A	B
URD-LM24-18	18"	20.00"
URD-LM24-19	19"	20.00"
URD-LM24-20	20"	20.00"

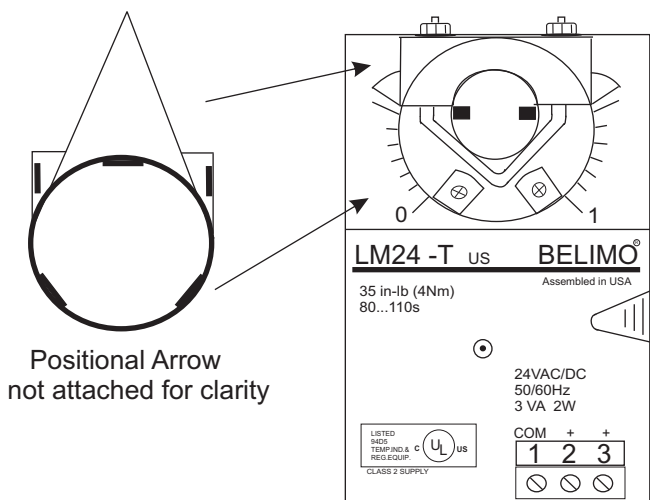

WIRING SOLUTIONS

MOTOR Terminal Output

- M6 - power to close
- M4 - power to open
- M2 - constant power
- M1 - common

Wiring to a Control Panel

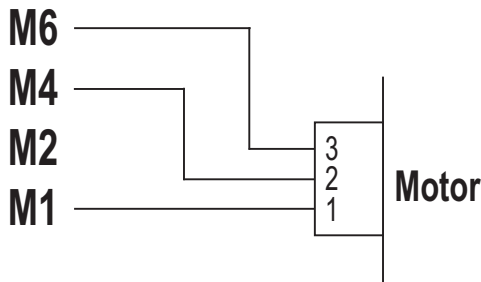

Wiring a Thermostat to Control a Single Damper

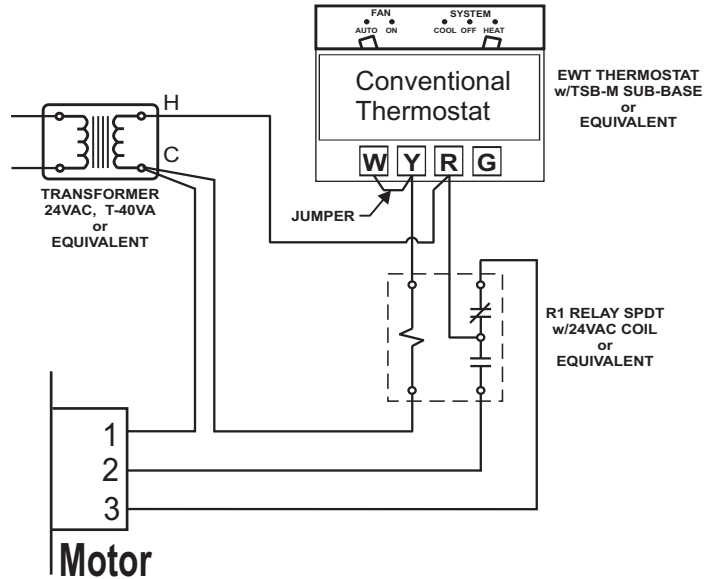

Wiring in Parallel

