



Whole House Humidifiers

FOR USE WITH ALL FORCED AIR SYSTEMS

**Installation Instructions
Owners's Manual**

**MODEL'S 200P, 800BP
and 97 POWER HUMIDIFIERS**

SEQUENCE OF OPERATION

The AUTOFLO Model's 200P, 800BP and 97 Humidifiers use the evaporative by-pass principal to add moisture into the return air duct of your central heating system. A bypass humidifier depends upon the air pressure difference between the warm air (supply) duct and the cold air (return) duct of the furnace. This pressure differential causes a portion of the warm air to flow from the supply to the return through the humidifier. A water pan at the bottom of the humidifier serves as a reservoir. The water level in the reservoir is automatically controlled by a float valve assembly. The motor driven media wheel is partially submerged in the water pan and partially exposed to the warm air flowing through the humidifier. Upon a demand for humidity from the humidity control, water is evaporated as the by-pass system forces warm air through the wet rotating media wheel. When this moisture laden air enters the return air duct it is mixed with cool dry air flowing through the duct. This air mixture will gradually increase the relative humidity in the home or office.

RECOMMENDED LOCATION

TEMPERATURE AND SAFETY REQUIREMENTS

Refer to the rating plate on the furnace for minimum clearances to combustible construction. All parts and connections of an AUTOFLO humidifier must be installed outside of the minimum clearance requirements for rear, top, sides, and flue of furnace. Do not install where humidifier or water connections may be exposed to freezing temperatures or outside weather.

Attic installations are NOT recommended. If you have central air conditioning, carefully plan the location of the plenum opening to prevent damage to the cooling coil or other devices inside the duct.

HUMIDIFIER MOUNTING LOCATION

All of the above models can be mounted on the supply or the return duct of the furnace. Plan your location carefully with ease of installation & service in mind.

STEP BY STEP INSTALLATION

CAUTION: Installation should be performed by qualified personnel only. Use eye protection and gloves when drilling and handling sheet metal. All work must be performed to local & national codes and ordinances. Use multi-conductor 18 awg solid copper wire. Provide over-current protection as required. DO NOT omit the drain or overflow tubing.

ATTACH TEMPLATES AND CUT OPENINGS

Tape the mounting template to the chosen location. Use a level or plumb line to make sure the template is level. Before proceeding, verify that adequate clearances are available for servicing the media wheel and removing the water pan. If necessary relocate the template. Extend and bend the by-pass duct and check to see if it will reach from the face of the by-pass template to the side of the humidifier template. If by-pass duct is not long enough, relocate the templates. If necessary, additional lengths of by-pass ducts are available from your local home center. Drill (6) 1/8 inch holes as indicated on the templates. Drill or punch a starter hole and then use a pair of sheet metal snips to cut out the opening. Remove the templates and tape.

INSTALL HUMIDIFIER

Install (2) 3/4 inch long sheet metal screws halfway in to the two upper most holes that were drilled through the mounting template. Hang the Autoflo model 200P, 800BP or 97 from the two long screws on the top lip. Install (4) 3/8 long sheet metal screws through the side flange and then tighten all six screws.

INSTALL DUCT ADAPTOR

Mount the duct adaptor to the by-pass opening with (2) 3/8 inch long sheet metal screws. Install the baffle between the duct and the adaptor. The baffle should be open during the heating season and closed for cooling season. Install and tighten the remaining (3) 3/8 inch long screws.

TB 219 Part# 090375A0219 Rev. B

Copyright 2003 © EWC Controls Inc., All Rights Reserved

EWC Controls Inc. 385 Highway 33 Englishtown, NJ 07726 • 800-446-3110 • FAX 732-446-5362 • E-Mail- info@ewccontrols.com

HUMIDISTAT MOUNTING LOCATION

The humidistat can be mounted on the cold air return duct to sense the cool dry air returning to the furnace. Mount the humidistat a minimum of 5 feet upstream of the bypass connection to the return air duct. The humidistat can also be mounted on an interior wall near the furnace thermostat as well. The electrical connections and basic wiring are the same for duct mounted or wall mounted humidistats.

INSTALL BY-PASS DUCT AND END CAP

Route the by-pass duct from the duct adaptor to the side of the humidifier. Drill two holes through the by-pass duct and duct adaptor and install (2) 3/8 inch long sheet metal screws. Each of the flanges on both sides of the humidifier have two pre-punched holes. Use these holes as guides and carefully pierce the by-pass duct from the inside of the humidifier. Use (2) 3/8 inch long sheet metal screws and attach the end cap to the other end of the humidifier to seal off the unused end.

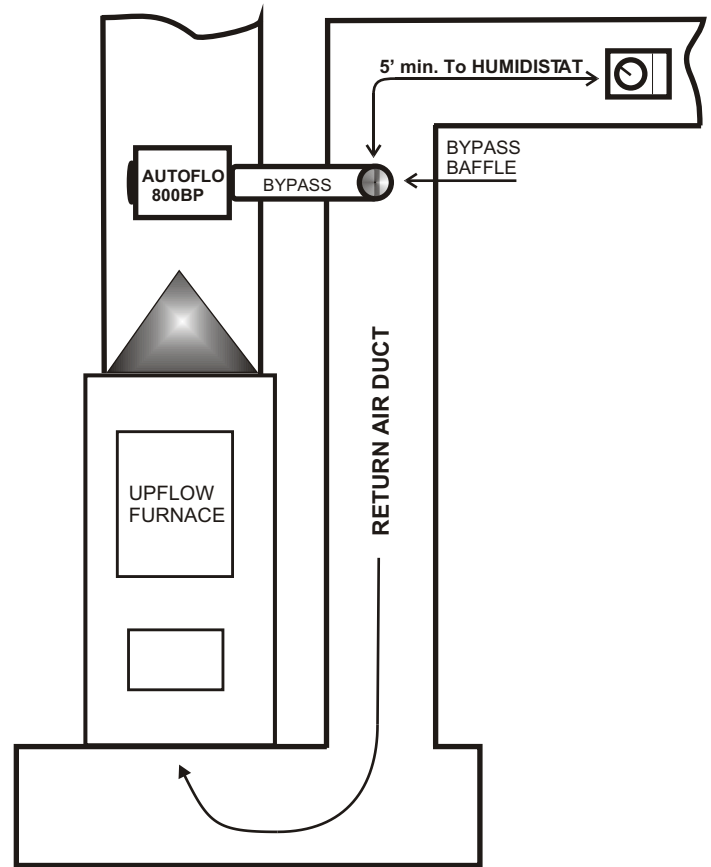

Typical field configurations for UP FLOW and HORIZONTAL FLOW furnaces and air handlers. Your actual configuration may vary. Keep the bypass duct as short as possible. The bypass duct should *never* be routed across the front of the furnace. All furnace access doors and openings must remain unobstructed for proper furnace operation and servicing. Remember to cap off the unused end of the humidifier.

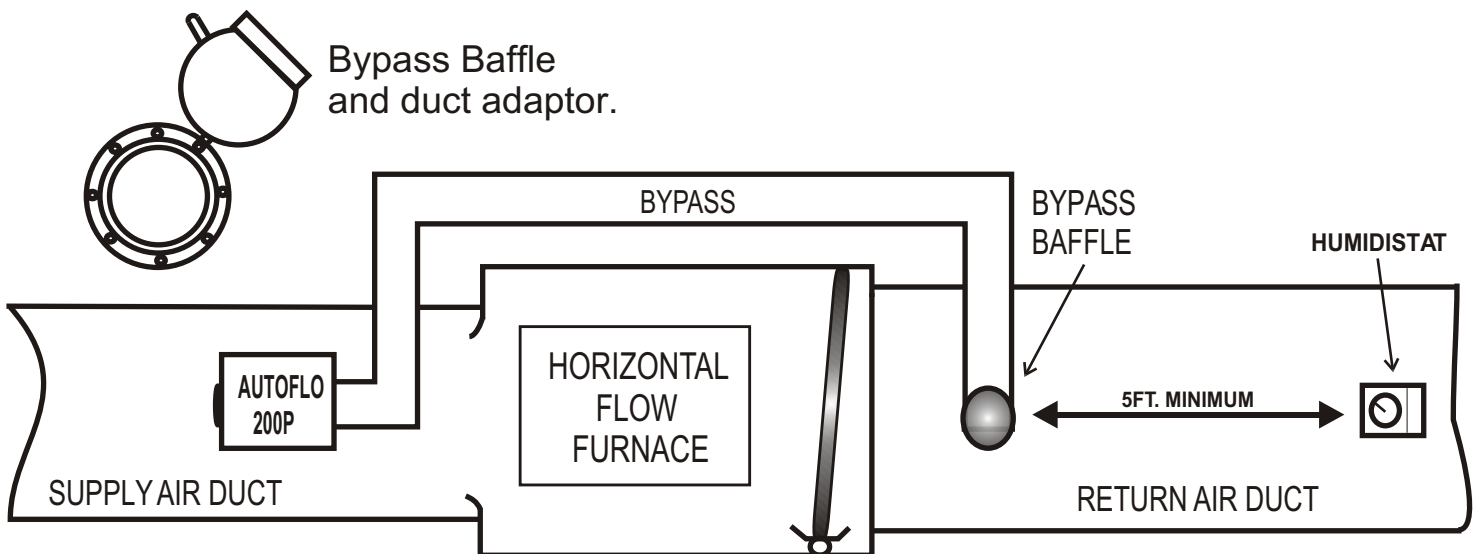

PARTS LIST

1. Model 200P Humidifier
2. Small parts bag containing:
 - a. Two #8 x 3/4 sheet metal screws
 - b. Seventeen #8 x 3/8 sheet metal screws
 - c. Strain relief
 - d. Two wire nuts
3. 24vac transformer
4. End cap
5. Baffle
6. Duct adaptor
7. 1/4 inch plastic tubing
8. Saddle tapping valve kit

9. Mounting template (Not Shown)
10. By-pass adaptor template (Not Shown)
11. Autoflo 24vac humidistat
12. Drain tubing

ADDITIONAL RECOMMENDED PARTS

1. Current sensing relay
2. Small hose clamp for drain tubing.
3. Electrical wire and enclosures for both line voltage and 24vac connections



PARTS LIST

1. Model 97 Humidifier
2. Small parts bag containing:
 - a. Two #8 x 3/4 sheet metal screws
 - b. Seventeen #8 x 3/8 sheet metal screws
 - c. Strain relief
 - d. Two wire nuts
3. 24vac transformer
4. End cap
5. Baffle
6. Duct adaptor
7. 1/4 inch plastic tubing
8. Saddle tapping valve kit

9. Mounting template (Not Shown)
10. Autoflo 24vac humidistat
11. By-pass adaptor template (Not Shown)

ADDITIONAL RECOMMENDED PARTS

1. Current sensing relay
2. Electrical wire and enclosures for both line voltage and 24vac connections



PARTS LIST

1. Model 800BP Humidifier
2. Small parts bag containing:
 - a. Two #8 x 3/4 sheet metal screws
 - b. Seventeen #8 x 3/8 sheet metal screws
 - c. Strain relief
 - d. Two wire nuts
3. 24vac transformer
4. End cap
5. Baffle
6. Duct adaptor
7. 1/4 inch plastic tubing
8. Saddle tapping valve kit

9. Mounting template (Not Shown)
10. By-pass adaptor template (Not Shown)
11. Autoflo 24vac humidistat (Not Shown)

ADDITIONAL RECOMMENDED PARTS

1. Current sensing relay
2. Small hose clamp for drain tubing.
3. Electrical wire and enclosures for both line voltage and 24vac connections



MODEL 200P, 97, 400/800BP POWER HUMIDIFIERS

ELECTRICAL CONNECTIONS.

The transformer should be wired in parallel with the furnace blower motor line voltage. This will allow the humidifier to run only when there is a call for fan. The transformer is designed to be attached to a 4" square outlet box. The electrical box must be mounted and wired in accordance with local building codes & the National Electrical Code. **SHUT OFF THE POWER TO THE FURNACE BEFORE PROCEEDING!** **NOTE1:** Check wiring in furnace for humidifier (HUM) terminals. If present, check to see if it is 120vac or 24vac. If it is 120vac connect the transformer primary leads to these terminals. If it is 24vac, you don't need the transformer. Simply connect one side of the humidistat to one HUM terminal and the other HUM terminal to the motor of the humidifier. Then make the last connection of the motor to the humidistat. If you are using the transformer you will need to connect the 24vac common from the transformer to one of the motor wires and then the 24vac hot from the transformer to the humidistat. Then from the humidistat to the other wire on the motor. Make sure not to route wires where they can be burned or chaffed. See example wiring solutions to the right of this page.

OPERATIONAL CHECK

With the humidistat set to its highest setting the motor should start shortly after the furnace blower is activated. If motor does not start refer to troubleshooting guide in this manual.

CAUTION: Check the transformer, the motor, humidistat and any other field installed devices, as well as all field wiring.

A qualified Electrician should be consulted to determine if line voltage is present at the transformer and that 24vac is present at the humidistat and at the motor.

WIRING FOR MOST COMMON FURNACES

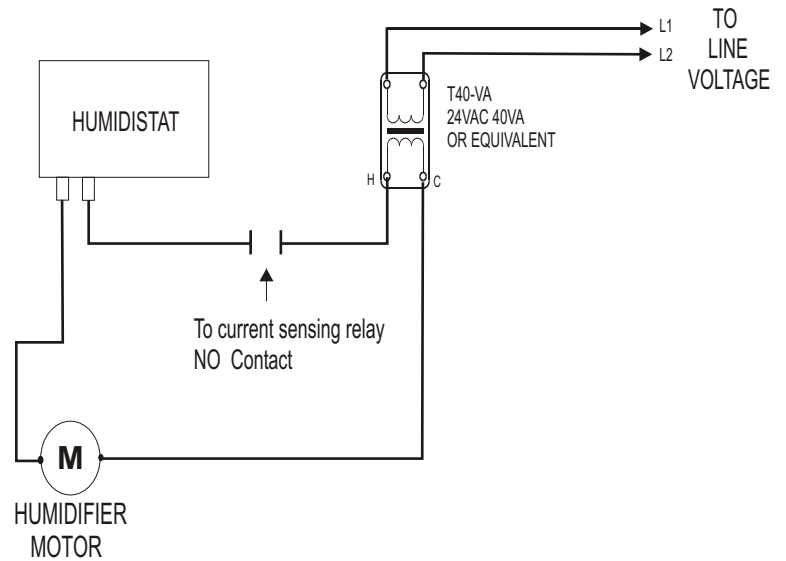

WIRING FOR COMMON 2 STAGE OR VARIABLE SPEED FURNACES

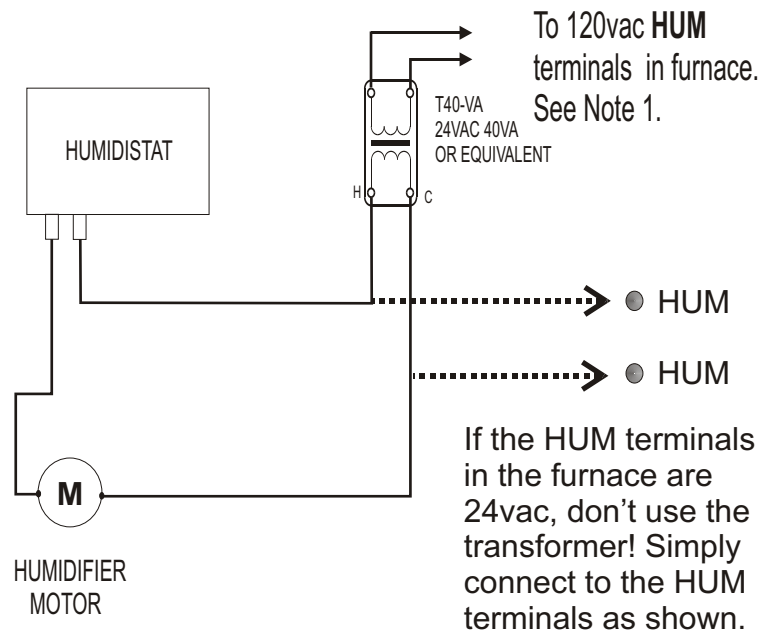

WATER CONNECTION

Water supply for the humidifier must be taken from a nearby water line. If the humidifier is installed in, above, or adjacent to a decorated living area, an emergency overflow pan is required below the humidifier. Do not use any line connected to an air conditioning coil. Lines connected to an a/c coil normally contain refrigerant not water. Do not use any line serviced by a water softener, make the water connection up stream of the water softener. A water softener is not a de-mineralizer. It merely exchanges hard-ions for soft-ions in the water. These soft-ions or minerals, will build up in the humidifier, causing a need for frequent servicing. The evaporation of softened water may also produce a white powder which may be carried in to the duct work and ultimately in to the your home. You have been supplied with 10 feet of plastic tubing for making the water connection. If more tubing is needed, longer lengths of ¼ inch OD plastic or copper tubing is available from your local home center. Follow the instructions on the saddle tapping valve kit and install the valve. The valve should be mounted on top or on the side of the water line to prevent the valve from clogging with any sediment from the water line. Prior to connecting to the float, open the valve and flush the water line into a bucket. This will clear any sediment from the line that may clog or impair the float operation. *Attic installations are not recommended.*

FLOATADJUSTMENT

Remove the front cover and check the water level. The float has been set at the factory for normal water pressure conditions. The float should completely shut off the water flow when the water level is 1-1/4 inches to 1-3/4 inches above the bottom of the pan. If additional adjustment is needed, adjust the float bulb screw located on top of the float arm above the bulb. Turn the screw clockwise to lower the water level, turn it counter clockwise to raise the level. The hex nut may be loosened and the entire float assembly may be moved up or down to adjust the water level. *Adjustment of the crutch screw is not recommended.* You should maintain a water level that is high enough to wet the media wheel as it turns, but not so high that water runs out of the overflow spout. Refer to the drawing on this page.

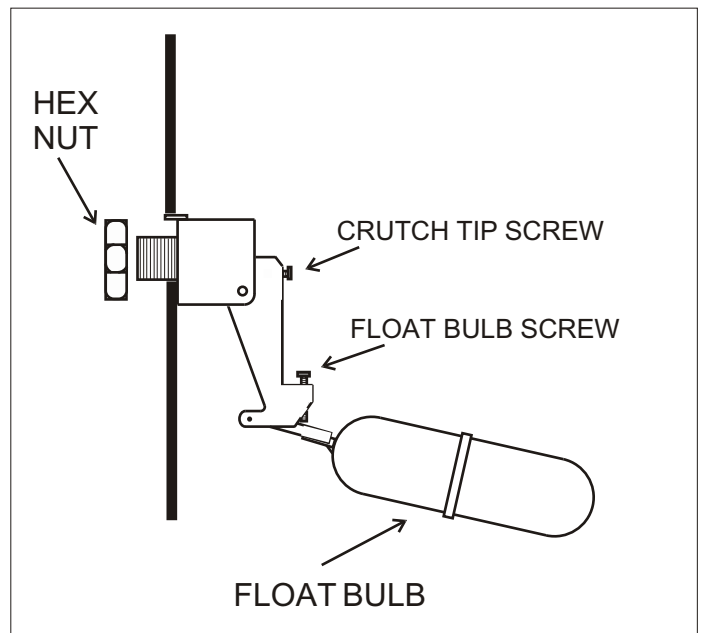

DRAIN CONNECTION

We recommend that a drain line be used as an emergency overflow for the model's 200P, 800BP, 97 humidifiers. Use a hose clamp to connect the supplied drain hose to the overflow spout, if available. The spout is on the right-hand side of the water pan. Do not use rigid piping because the water pan must be removable for routine cleaning and service. Keep the hose as short as possible and avoid sharp bends. The drain line should be routed on a continuous downward slope and into a suitable drain.

SETTING THE HUMIDISTAT

The proper relative humidity for your home depends upon several factors such as outdoor temperature, type and placement of insulation, vapor barriers, quality of windows and doors (including frames and jams), and effectiveness of weatherstripping. With all these variables it is nearly impossible to recommend a single proper humidity setting. The best humidistat setting is one that you are comfortable with.

As the outdoor temperature fluctuates, it may be necessary to adjust the humidity level in your home several times during the season. Refer to the "**Relative Humidity Chart**" as a starting point for your proper humidistat setting. In a tight, well insulated house, the humidistat may be set higher than in a drafty, poorly insulated house.

MAINTENANCE

DO NOT OVER-HUMIDIFY

Cold air cannot hold as much moisture as warm air. Any cold drafts or cold-faces such as windows and doors (including frames and jams) may cause water vapor to condense at these points. Also, if your home is well-insulated and weather-stripped but lacks effective vapor barriers, water may seep through the walls and ceilings. This moisture may condense either inside or outside the walls or in the attic. If any of these condition are observed, the humidity level should be reduced before water damage occurs. Consider purchasing a model 072000 Smart Humidistat. The 072000 monitors the outside air temperature and automatically adjusts the RH set point as the outdoor temperature falls below 35 degrees F.

RELATIVE HUMIDITY CHART

Suggested Humidistat Settings

OUTDOOR TEMPERATURE	ADJUST %RH TO
+30°F	40%
+20°F	35%
+10°F	30%
+0°F	25%
-9°F	20%

Suggested RH set points for different outdoor temperatures

All power humidifiers require some maintenance to keep them operating at peak performance. The autoflo model 200P, 800BP, and 97 humidifiers have been designed to simplify this required maintenance routine. Proper maintenance of your autoflo humidifier should include the following three procedures:

1. Annual replacement of the evaporator pad.
2. An occasional cleaning of the water pan.
3. An annual cleaning, general inspection and shut down of the unit.

The evaporative pad should be replaced with the one for your model humidifier for model 200P, use a catalog # 200EP pad. For a model 800BP, use a catalog #200EP. For a model 97, use catalog #97EP. When the pad becomes clogged or brittle it needs to be replaced. The rate of evaporation depends upon both the surface area of the pad and the ability of the air to pass through the pad. To remove the pad, turn off power to both the humidifier and the furnace. Open the service door and lift the rear of the wheel. Disengage the front of the wheel from the motor and lift the wheel and pad up and out. To clean the water pan, turn off the water at the supply valve. Remove the drain line from the water pan. Locate the two thumb screws which are located on each side of the humidifier. When you remove these screws the water pan **which is full of water** will be free to fall downward. With this in mind, hold the bottom of the pan with one hand and loosen the thumb screws with the other. Support the water pan in a level position until the water can be dumped into a suitable receptacle. Remove mineral deposits from the water pan. A mild detergent or vinegar and water solution is acceptable for cleaning the pan. When replacing the water pan, the float must be gently lifted into position. This will prevent damage or bending of the float assembly. Reinstall the two thumb screws and attach the drain line. Turn on the water supply to the humidifier, check the float operation and check for leaks. Annual (spring) shut-down should consist of replacing the evaporator pad, thoroughly cleaning the water pan and rotating the by-pass baffle to the closed position. After performing these procedures, leave the water and electrical power off to the humidifier for the summer or cooling season. To restart the humidifier in the fall turn on the water supply, power up the humidifier and rotate the baffle to the open position. Set your humidistat to the desired setting.

T R O U B L E S H O O T I N G

SYMPTOM	POSSIBLE CAUSES & REMEDIES
Improper water level(water is to high or to low)..	<ol style="list-style-type: none"> 1. Float is not adjusted properly. Adjust float per page 7 instructions. 2. Float is defective. Replace float.
Water does not flow in to pan at all. Or water flows into the pan very slowly. Unable to maintain proper water level.	<ol style="list-style-type: none"> 1. Float is not adjusted properly. Adjust float per page 7 instructions. 2. Float is defective. Replace float. 3. Saddle valve "T" handle is not open. Open the valve. 4. Saddle valve is clogged. Replace or clean the valve. 5. Water supply line is clogged or kinked. Repair or replace the line.
The media wheel is not rotating when the furnace blower is running and/or the motor does not turn when heat is activated.	<ol style="list-style-type: none"> 1. The humidistat is not set high enough. Increase the setting. 2. The media wheel shaft is not properly aligned with the motor shaft. Re-align the media wheel shaft to the motor shaft. 3. 24vac is not present at the motor. Check field controls & wiring. 4. 24vac is present at the motor, but doesn't turn. Replace motor.
Not getting enough humidity.	<ol style="list-style-type: none"> 1. The humidistat is not set high enough. Increase the setting. 2. Media wheel is not wet due to low water level. Adjust the float. 3. Media material is old and brittle. Replace the media material. 4. Media type humidifiers operate only when the heating system is running. Several days or even weeks may be required to raise the humidity level in a very dry house. Consider a Steam Humidifier. 5. Unit is undersized for the home. Consider a Steam Humidifier.
Water in the pan is brackish or moldy. Humidity is not high enough.	<ol style="list-style-type: none"> 1. Poor or no maintenance is the primary reason for moldy water, moldy pans and poor performance. Annual spring shutdown should include: <ol style="list-style-type: none"> A. Shut-off the water supply. B. Remove and clean the pan with vinegar/water mixture. C. Dry the pan thoroughly and re-install it. D. Install new Media material and dispose of the old one. E. Thoroughly dry all surfaces and components inside the unit. F. DO NOT turn the water supply back on until the next humidifying season. Allowing water to sit in the pan for long periods of time will result in moldy water. G. Consider replacing the media material midway through the humidifying season.

TECHNICAL SUPPORT

EWC Controls provides superior toll free Troubleshooting Support for the AUTOFLO products when you are on the job site!

Call 1-800-446-3110 Monday - Friday 8am to 5pm EST

Otherwise call 1-732-446-3110 for information on any AUTOFLO products including model 200P, 400/800BP, and 97.

When calling for Technical Support, please have a multi-meter, pocket screwdriver, and wire cutter/stripper handy.

SERVICE NOTES

BLANK

BLANK